



**RELIANCE  
ELECTRIC**

*Custom  
Classics*

Reliance Electric  
Control Products  
2004/2005  
Catalog

**Rockwell  
Automation**

**Important User Information**

This catalog has been developed as a quick reference for Reliance Control Products. It is not intended to provide operational instructions or to replace user manuals or technical documentation which should be referenced to for actual installation, connection, operation, and maintenance of your Reliance equipment. Appropriate Reliance Electric Industrial Company instruction manuals and warning tags attached to the apparatus should be read carefully prior to installation, operation and/or maintenance of equipment.

Because of the variety of uses for the products described in this publication, those responsible for the application and use of this control equipment must satisfy themselves that all necessary steps have been taken to assure that each application and use meets all performance and safety requirements, including any applicable laws, regulations, codes, and standards.

The illustrations, charts, diagrams, and layout examples shown in this guide are intended solely for purposes of example. Since there are many variables and requirements associated with any particular installation, Rockwell Automation does not assume responsibility or liability (to include intellectual property liability) for actual use based upon the examples.

Prices shown on published price lists and other published literature issued by the company are not unconditional offers to sell and are subject to change without notice. All published and quoted prices are based upon the application of, and all sales are expressly subject to, the Company's Standard Terms and Conditions of Sales. Copies of the Company's Terms of Sales are available upon request.

Reproduction of the contents of this copyrighted publication, in whole or in part without written permission of Rockwell Automation is prohibited.

General  
AutoMax Network Architecture  
Overview – AutoMax Distributed Control System  
Approvals/Certification/Registration

**Processors/Racks/Power Supplies**

**1**

**Communications**

**2**

**Input/Output System**

**3**

**Programming Support Tools**

**4**

**Operator Interface Products**

**5**

**3rd Party Products**

**6**

**Rockwell Automation Support**

**7**

# AUTO MAX<sup>®</sup>

DISTRIBUTED CONTROL SYSTEM

## AutoMax Network Architecture

AutoMax provides a wide range of network connectivity modules including

- AutoMax DCS-Net
- AutoMax Remote I/O
- A-B Data Highway
- A-B Data Highway Plus
- ControlNet
- DeviceNet
- Ethernet
- Modicon ModBus
- Modicon ModBus Plus
- Reliance R-NET

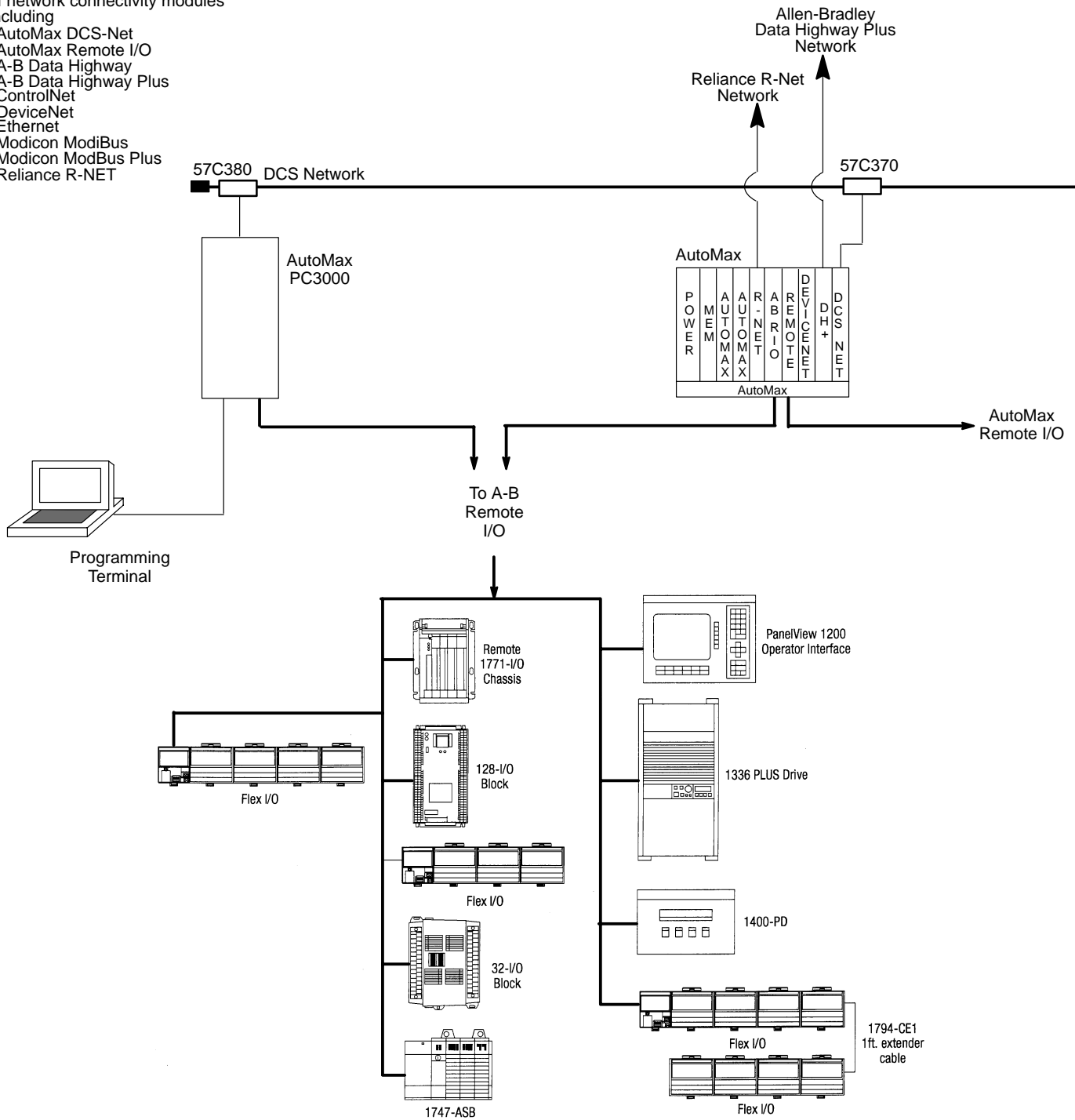

200 63R

# AUTO MAX<sup>®</sup>

DISTRIBUTED CONTROL SYSTEM

## AutoMax Network Architecture

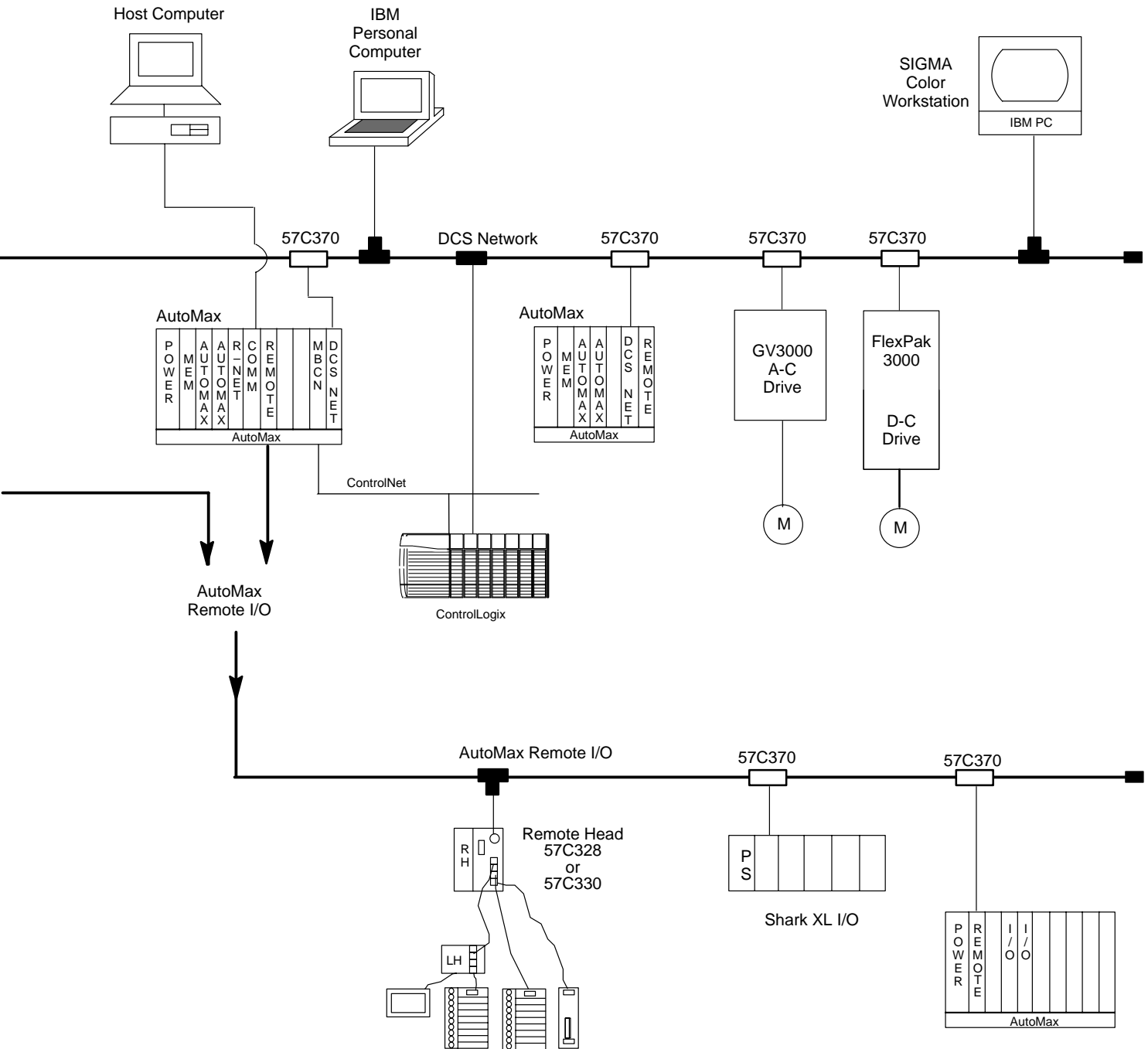

---

# AUTO MAX<sup>®</sup>

DISTRIBUTED CONTROL SYSTEM

---



## AutoMax – A Powerful Combination of Controls

Today's challenge in industrial control is to simplify the task of designing, implementing, and maintaining complex automation and control systems. The natural solution is to divide the complexity into manageable segments, distribute the control function throughout the plant or process, and provide an exchange of information between these segments.

The AutoMax Distributed Control System provides many of the same functions of expensive process controllers – at savings up to half the price. The AutoMax system's "real-time" operating system also provides the user with advanced programming tools not available in typical programmable controllers. And, with its loadable run-base architecture, future product upgrades are easily installed.

The AutoMax Distributed Control System is ideal for applications that require millisecond response times and that incorporate sequence control, process control, data collection, or complex math. Applications can range from stand-alone to multi-rack distributed control installations.

AutoMax is fully compatible with Reliance's DCS 5000 Industrial Controller and incorporates many of its field-proven features. AutoMax can be linked to the AutoMate<sup>®</sup> programmable controllers, via R-Net and to Allen-Bradley controllers via standard networks using Data Highway Plus.

Using the AutoMax, an industrial control system can be partitioned into subsystems which communicate with each other, yet operate as totally self-contained units. Each subsystem is further subdivided into modules that have distinct functions operating in a coordinated manner.

Additionally, the AutoMax System Software separates the required functions of the system into distinct tasks that operate concurrently (multi-tasking) on a priority basis while sharing system data and control signals. The System Software further subdivides the tasks into high level, control, and sequential logic operations and contains three separate languages (BASIC, Control Block, Ladder Logic) to program them.

## Hardware Configurations To Complement The System Requirements

The flexibility of AutoMax allows the control system designer to select the hardware configuration best suited to the application.

A typical AutoMax System is made up of one or more units. Each unit can be Multibus rack based or PC-card based depending the system parameters. The rack based units consist of power supply and chassis with various types of processor, input/output and communications modules. The PC-Card based units are either installed in stand-alone packaged versions, which also provide the power supply necessary for the PC-Card module as well as a serial interface module or the module is installed in one of the customers PC computers. The PC-Card modules are complete with built-in DCS-Net and A-B Remote I/O ports.

The units communicate with each other using the DCS-Net network. They also connect to I/O via remote I/O networks. The System provides sharing of data between units as well as between programs in the same unit. In addition, the Multibus based rack units provide for coordination between multiple processors in the same rack. This communications and data sharing allows the industrial control function to be distributed among multiple units.

- **Loadable run base** greatly simplifies the incorporation of future enhancements to the system. The operating system is loaded into the AutoMax from a cd.
- **Multi-processing capability** lets you add more processor power in the AutoMax rack when you need it. . .without rewriting your application software.
- **Multi-tasking** makes program development, checkout and support easier by allowing the software to be broken into logical parts or tasks. The AutoMax permits concurrent operation of multiple tasks within a processor according to the priorities you assign.
- **3 programming languages** are available to program AutoMax tasks: Ladder Logic, Control Block and Enhanced BASIC. The user chooses the most effective language for programming each task.
- **High-speed network** allows information to be shared easily between AutoMax racks, thus freeing the user to configure the hardware for the most cost effective installation.
- **Remote I/O capability** lets you place the I/O near the equipment to be controlled for reduced wiring costs.
- **Built-in diagnostics**, coupled with on-board status LEDs and digital displays, help to make for reliable operation and easy troubleshooting.
- **Communications to non-AutoMax devices**, such as CRTs and host computers, is simple through the use of available network interfaces and serial ports.

- **IBM PC – compatible programming executive** features full documentation, on-line process monitoring, ladder logic modifications, and program upload and download capability.

### A Multi-Use Controller

The design of the AutoMax incorporates many features that allow the hardware and software to function effectively and efficiently in many types of stand-alone and multi-unit distributed industrial control installations.

### Multi-Tasking Operating System

The AutoMax Software Operating System provides the real-time concurrent operation of multiple programs or tasks on the same processor on a priority basis, while sharing system data and control signals. Though only one task runs at a time on the same processor, the execution of the tasks is scheduled so that each task shares the processor over a period of time. This multi-tasking permits the user's overall control scheme to be separated into individual tasks which simplifies writing, checkout and maintenance of the application program. Multi-tasking in the AutoMax also reduces overall execution time and provides a faster response to critical tasks.

### Multi-Processing Hardware

In the rack based units, internal communications of the AutoMax are based on the widely used and accepted bus structure, Multibus by Intel. Multibus, field proven by years of industrial use, provides a highly dependable base on which to build a very reliable product.

By choosing Multibus, Reliance Electric has insured that the AutoMax will meet the demanding requirements of industrial control today and in the future.

Utilizing the Multibus standard and the AutoMax operating system allows the implementation of a unique multi-processing architecture in the AutoMax. Multi-processing is a solution to requirements for additional I/O, speed, memory, and processing power in industrial control applications. The AutoMax will accommodate up to four Processor Modules in the Multibus rack along with a Common Memory Module. Other cards such as the Network and Remote I/O Communication Modules, Interface Modules and the general I/O Modules can be inserted in the rack as space permits. The unique feature of the AutoMax multi-processing system is that program tasks are transportable from processor to processor – expansion requires no reprogramming of existing tasks. Memory used to store process parameters and data in any of the Processor modules is accessible by other Processor Modules and this access is transparent to the user.

### Multi-Language Programming

In conjunction with its Multi-tasking Operating System, the AutoMax also provides three separate languages for programming, each tailored to a specific need.

The LADDER LOGIC language is used for sequencing operations and discrete input/output. It allows the user to program the I/O and internal contacts and coils with easily recognizable names.

The CONTROL BLOCK language is used for analog regulation and process control. The blocks are preconfigured control statements that allow the user to easily specify control strategies.

The ENHANCED BASIC is used for arithmetical operations, numeric and string handling, and host computer communications. The ENHANCED BASIC tasks link the AutoMax to keyboard and CRT-based operator interface devices. The CONFIGURATION task sets the priority and scheduling of all of the various Ladder Logic, Control Block, and BASIC tasks in the application program and defines all system I/O.

### Programming Systems

IBM Based Development Executive Software

### DCS Network

56 nodes (1 master, 55 slaves), 1.75 mbaud, Multidrop configuration 3000 ft. with Belden 9259 or equivalent coaxial cable.

### AutoMax Remote I/O System

Up to 15 remote I/O processors can be installed in each master rack. Each remote I/O network provides for up to 7 remote I/O drops.

### Allen-Bradley Remote I/O System

Up to 15 remote I/O processors can be installed in each master rack. Each remote I/O network provides for up to 7 remote I/O drops.

### AutoMax Specifications

#### Power Requirements

Input power: 120 VAC 50/60 Hz (+10%, -15%)  
 Output power: 50 amps @ 5 VDC

#### Environment

Operating temperature range: -0 to +60°C  
 Storage temperature range: -40 to 85°C  
 Humidity range: 5 to 90% Non-Condensing

---

# **AUTO**MAX<sup>®</sup>

DISTRIBUTED CONTROL SYSTEM

---

## **AutoMax Processors**

AutoMax 6011: Motorola 68010, 8 mHz clock rate

AutoMax 7010: Motorola 68020, 25 mHz clock rate

AutoMax PC3000: Motorola 68040, 25 mHz clock rate

AutoMax 6011 and 7010 processors can be mixed in the same rack. All processors may be programmed over the DCS-Network. The 6011, 7010 and the PC3000 packaged version processors each have 2 serial ports. The PC3000 processor does not have serial ports.

\* IBM-PC is a trademark of International Business Machines.  
Motorola 68010, 68020 and 68040 are trademarks of Motorola Corporation.  
Data Highway and Data Highway Plus are trademarks of Allen-Bradley Company, Inc.  
Modbus and Modbus Plus are trademarks of Modicon.  
Multibus is a trademark of Intel Corporation.



**AUTOMAX**<sup>®</sup>

DISTRIBUTED CONTROL SYSTEM

## Approvals/Certification/Registration

### UL Approval

Generally, we pursue applicable UL approval for our products. There are two relevant types of approval granted by Underwriters Laboratories (UL):

- **UL Recognized:** If a product was UL Recognized at the time this catalog was printed, we included the following either in its specification section or in the UL/CSA information at the end of each section:

#### UL Recognized

- **UL Listed:** If a product was UL Listed at the time this catalog was printed, we included the following either in its specification section or in the UL/CSA information at the end of each section:



**Actual UL approval is indicated by the label on the product and not by statements in this catalog or any product literature.**

### CSA Certification

Generally, we pursue applicable CSA certification for our products. CSA certifies products for general use as well as for use in hazardous locations. Products in this catalog might be certified in one of these two ways:

- **CSA Class 1, Division 2 Hazardous Location Certification:** This product is listed by the Canadian Standards Association as certified for use in Class 1, Division 2, Group A, B, C, D, or non-hazardous locations only. If a product possessed this certification at the time this catalog was printed, we included the following either in its specification section or in the UL/CSA information at the end of each section:



#### Class 1, Division 2 Hazardous

- **CSA Normal Certification:** The product is listed by the Canadian Standards Association as certified for non-hazardous locations. If a product possessed this certification at the time this catalog was printed, we included the following either in its specification section or in the UL/CSA information at the end of each section.



**Actual CSA certification is indicated by the label on the product and not by statements in this catalog or any product literature.**

### ISO 9000 Registration

Reliance Electric has registered business groups and facilities, encompassing 17 separate sites and its major product families, to ISO 9000 standards. The Reliance Control Group's primary manufacturing facilities are registered to ISO 9001. This registration means that our quality system governing the design, development, manufacture, delivery and internal customer service processes for our products has been verified by third party audits.

### European Union Council

Directives: 89/336/EEC Electromagnetic Compatibility (EMC) and 73/23/EEC Low Voltage.



## Notes

---



DISTRIBUTED CONTROL SYSTEM

## Processors/Racks/Power Supplies

---

### AutoMax Racks/Power Supplies

Racks .....	1-2
Power Supplies .....	1-3

### AutoMax Processors

AutoMax Multibus Processors .....	1-4
AutoMax PC3000 Processor .....	1-5
AutoMax Common Memory Cards .....	1-6

### Selection Charts

Racks .....	1-7
Power Supplies .....	1-7
Processors .....	1-8
Common Memory Cards .....	1-8
Upgrades .....	1-9
Rack/Chassis Dimensions .....	1-10
Module Power Supply Requirements .....	1-11

## Multibus Card Racks

Model Nos. 57C331, 57C332, 57C334

---

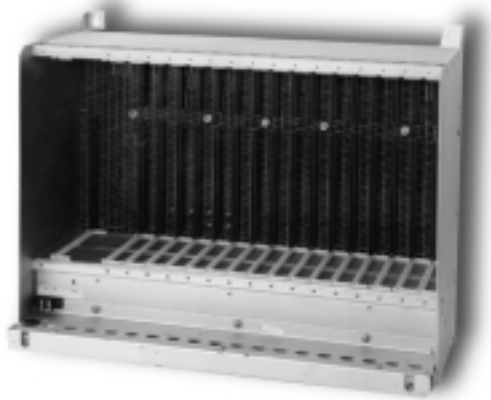

### Features

- 6, 10 and 16-Card Slots (excluding power supply)
- Custom card guides
- AC line filter
- High-capacity cooling fans
- Cable management tray



**57C331** 16-Card Module Slots, Panel Mount

**57C332** 10-Card Module Slots, Panel Mount

**57C334** 6-Card Module Slots, Panel Mount

The card module Rack is the basic component of the AutoMax system. The assembly is used as a Master Rack and as the remote I/O chassis. With Power Supply Module installed, the Rack distributes all power required to operate the AutoMax card modules.

The AutoMax Rack provides the mechanical means for mounting any of the AutoMax Modules. The Multibus backplane of the Rack supports two sets of bus lines, P1 and P2.

The P1 bus, the larger of the two electrical connectors, conforms to the IEEE Microcomputer System Bus Standard for the P796 (Multibus). This standard strictly defines both the electrical interfacing and mechanical characteristics for both the Rack and AutoMax card modules. The P1 bus is used for communication and control signals among the different AutoMax modules.

The P2 bus, the smaller of the two backplane electrical connectors, follows a Reliance pin assignment as permitted by the IEEE P796 standard. The P2 bus is used for special purpose functions such as determining the position of the various AutoMax modules in their slot locations.

Because of the dedicated signal lines on the Reliance Multibus backplane, some modules have slot placement limitations.

- **57C493** or **57C494** Power Supply Module – must always be inserted at the leftmost side of the rack.
- **57C413** or **57C423** Common Memory Module – when used with multiple processors, must be in slot 0. Otherwise, may be used in any even numbered slot.
- **57C431** or **57C435** Processor Module – may be inserted in slots 0 through 4.

Refer to instruction manuals for further module slot restrictions.

**Power Supplies**

Model Nos. 57C493, 57C494



The Power Supply Module is a circuit assembly enclosed in a protective aluminum housing with integral heatsink. The Module plugs into the leftmost position of the AutoMax Multibus Rack and provides, through the Multibus backplane, all of the voltages necessary to power the logic circuitry of all card modules in the rack.

The Power Supply Module is the electrical interface between the 120V ac input power and the AutoMax System. The AC line filter located in the Multibus Rack is connected between the incoming power and the Power Supply Module. No other connections to the AC line are made between the line filter and the Power Supply Module.

On power-up, a soft-start feature gradually increases the output until five milliseconds after the voltage exceeds the volts necessary for logic operations. At this time, an initialize signal is generated and the P/S READY indicator is illuminated. The holdover time on loss of AC input is 20 milliseconds. Three milliseconds before loss of the regulated DC power, a Multibus power fail interrupt signal is generated for orderly system shutdown.

**Features****Power Supply Module 57C493**

- 50-amp supply
- Over-voltage protection
- Over-current protection
- LED status indicators
- Keyswitch
- Removable terminal strip
- Captive ejectors
- Hold-down screws
- Occupies 3 rack slots

**LED Status Indicators**

- POWER ON – Incoming AC power is within the specified ranges.
- P/S READY – The Power Supply is producing all required DC voltages within the specified ranges.
- SYSTEM READY – All Processor Modules in the Rack are functioning.
- BLOWN FUSE – The power is ON but the fuse line is open.

**Power Supply Module 57C494**

- 23 amp supply
- Over-voltage protection
- Over-current protection
- LED status indicators
- Keyswitch
- Removable terminal strip
- Captive ejectors
- Hold-down screws
- Occupies 2 rack slots

**LED Status Indicators**

- POWER ON – Incoming AC power is within the specified ranges.
- P/S READY – The power supply is producing all required DC voltages within specified ranges.
- SYSTEM READY – All processor modules within the rack are functioning.

**Both Modules:****Three-Position Keyswitch**

- PROGRAM – The program can be loaded, the state of the system changed, and variable data modified.
- NORMAL – The system status can be monitored but no changes can be made.
- SETUP – System status can be monitored and tunable variables modified.

**Terminal Strip**

- GND – Ground to Rack
- L2 – Connect to 120V ac neutral input line
- L1 – Connect to 120V ac hot input line

## Multibus Processors

Model Nos. 57C431, 57C435

---



### Family of Processors

The AutoMax DCS family of hardware and software solutions for complex control applications offers you a choice of processors to match your requirements for speed, power and memory.

The 6011 Processor commands a wide range of analog, digital and special input and output functions including AC and DC drive regulation and control. The 7010 Processor is three to six times faster than the 6011 Processor.

Based on 16- and 32-bit Motorola microprocessors, the AutoMax DCS family of processors gives you the ability to adjust the schedule of program tasks to within 0.5 msec. The AutoMax multi-processing capability allows you to include different processors in a given rack, as well as anywhere on the system. In addition, all software and programming are compatible with the entire family of processors.

### Features

- Two models of processors available. Application software is independent of model and can be run on any current AutoMax processor.
- Mix/match processors in a rack
- Network programming allows all processors on a network to be downloaded, monitored, modified, or documented from a single IBM compatible PC connected to the network.
- Run base (operating system) is downloadable to facilitate future upgrades.
- Two serial I/O communications ports
- "OK" LED
- Battery OK LED

The Processor Module executes the user application program tasks to coordinate and control all of the activities of the other modules in the AutoMax System. The Processor Module is a printed circuit assembly based on the M68000 family of microprocessor, with on-board battery backed RAM application and operating system memory. A protective enclosure contains the standard connectors to interface with the AutoMax System Multibus. The faceplate of the module contains two serial data ports which connect the AutoMax System to the programmer, and other serial peripheral devices, such as a printer, CRT, or host computer. Also on the faceplate are two 7-segment LED displays for fault and status codes, and a single "OK" LED which indicates that the Processor Module is functioning properly.

The AutoMax Software Operating System which runs the Processor Module is a real-time, multi-tasking executive that allows the user to program in any of the three available languages: Ladder Logic, Control Blocks, and Enhanced BASIC.

For multi-processing, a maximum of four Processor Modules can be installed in the same Rack. The multi-processing configuration also requires a Common Memory Module.

### LED Status Indicators

- OK – the Processor Module is functioning properly within the limits of the internal diagnostics.
- FAULT CODE – on two 7-segment LEDs, displays a two-digit code of the fault whenever an error condition is detected during power-up or normal operation.
- BATTERY OK – the lithium battery in the processor has sufficient charge to retain memory.

### RS-232C Communication Ports

- 2 serial ports are available on each processor. One port per rack is dedicated as a programming port. All other serial ports in the rack are under application software control for connection to peripherals such as printers and CRTs.

**Battery Part No. – 57C385**



**PC3000 Processor****Model Nos. 57C560, 57C570**

The PC3000 Family of AutoMax Processors offers the power and flexibility of the AutoMax Distributed Control System in a low-cost personal computer based hardware platform. This family of processors can be used by integrators, OEMs, and current AutoMax users who wish to make additions to current systems. The PC3000 includes the functionality of an AutoMax 7010 Processor, the AutoMax DCS Network, and the AutoMax A-B Remote I/O Scanner on a single ISA Bus compatible printed circuit board. The product is available as a single board which plugs into the backplane of a personal computer, or as a packaged unit which includes:

- PC3000 Processor Card
- Panel-mount industrial grade enclosure
- Passive 6 slot ISA backplane (4 slots available)
- 150 Watt Power Supply
- Serial Interface Card (Model No. 57C565)

The AutoMax PC3000 supports many of the features of the AutoMax Multibus system including:

- Multi-tasking
- Three Programming Languages
- Network Programming
- Downloadable Runbase for easy future upgrades
- AutoMax Version 4 Programming Executive (required for programming the PC3000)

The PC3000 *does not support* the following standard features of the AutoMax Multibus Rack product:

- Multi-processing
- Distributed Power System
- Communication Processors (other than the AutoMax DCS Network and A-B Remote I/O Scanner processors)

The following IBM PC Architecture standards are also supported:

- Data exchange over the PC ISA Bus
- Plug and Play

The AutoMax PC3000 is intended for use as a drive controller for Reliance Standard Drives (FlexPak 3000, GV3000) with the Network Option Board installed. Because of its direct connection to the PC ISA Bus, it may also be used for Man-Machine Interface (MMI) and Operator Interface (OI) in Reliance Systems. The AutoMax A-B Remote I/O Scanner connection enables the PC3000 to control any piece of hardware that can communicate over the A-B Remote I/O Network, including 1771 I/O, 1794 (Flex) I/O, 1746 (SLC) I/O, 1791 (Block) I/O, PanelView Operator Interface Terminals, ReddiPanel Stations, 1336 Force Drives, etc. This connection when used in concert with the AutoMax DCS Network connection will allow the control engineer to create a low-cost, high-performance drive system with many of the features found in today's AutoMax Systems. One or multiple drives may be controlled, depending on the physical length of the network and the level of performance required – please consult page 2-2 of this catalog for more detail on the operation and limitations of the Reliance AutoMax DCS Network.

**Battery Part No. – 57C385**



## Common Memory Cards

Model Nos. 57C413, 57C423

---



When used with a single Processor Module, the Common Memory Module provides an additional 64K or 128K words of memory for storage of the configuration task and system common variables.

The Common Memory Module is required when more than one Processor Module is used in the same AutoMax Rack and allows the processors to communicate with one another over the Multibus P1 bus. Even if the processors are performing totally unrelated tasks and do not need to communicate with each other at all, the Common Memory Module is still required to provide the bus arbitration signals so that the processors can share the bus.

The Common Memory Module is used to store symbol tables and other data structures required to allow tasks to be shared between Processor Modules. When a Common Memory Module is used, the system configuration task and a portion of the memory required by the software operating system are stored on this module rather than on the Processor Modules.

The system watchdog timers on the Common Memory Module are one level of system protection higher than the local watchdogs on the individual Processor Modules. When a Processor Module ceases functioning properly, all I/O Modules in the Rack are reset and all outputs are cleared. Any other Processor Modules in the Rack will detect that the processor has shut down through a signal from the Common Memory Module and will also shut down.

### Features

- Extends single processor data storage
- Permits multiple processor operation
- Provides high level system watchdog
- Battery backed up RAM with battery status word available to tasks

### LED Status Indicators

- OK – the Common Memory Module is functioning properly
- BAT OK – the battery is good

**Battery Part No. – 57C385**





**Selection Charts****Model Nos. 57C331, 57C332, 57C334, 57C493, 57C494****Multibus Racks**

Rack	Slots	Power Supply Required	P2 Bus	P1 Bus	Model Number
16 Module Rack	19 slots total 3 slots for Power Supply 16 slots for Modules	57C493 (3 Slot Supply) or 57C494 (2 Slot Supply) Note 1, Note 2	Reliance Pin Assignments	IEEE P796	57C331
10 Module Rack	13 slots total 3 slots for Power Supply 10 slots for Modules	57C493 (3 Slot Supply) or 57C494 (2 Slot Supply) Note 1, Note 2	Reliance Pin Assignments	IEEE P796	57C332
6 Module Rack	8 slots total 2 slots for Power Supply 6 slots for Modules	57C494 (2 Slot Supply) Note 2	Reliance Pin Assignments	IEEE P796	57C334

**Note 1:** A blank faceplate (model no. 61C599) is recommended to cover the gap between the power supply and slot 0 when the 2 slot supply is used in a 10 or 16 Module Rack.

**Note 2:** See Table on page 1-11 for power supply loading requirements.

**Power Supplies**

Supply	Input Voltage	Input Frequency	Output	Maximum Continuous Output Power	Isolation	Model Number
3 Slot Supply	100V ac to 132V ac nominal 120V ac	47 to 63 Hz nominal 50/60 Hz	+/-5V dc @ 50 Amps +/-15V dc @ 1.0 Amps +/- 12V dc @ 4.0 Amps	376 Watts	1500V ac input to output 600V dc output to rack	57C493
2 Slot Supply	85V ac to 132V ac nominal 120V ac	47 to 63 Hz nominal 50/60 Hz	+/-5V dc @ 20 Amps +/-15V dc @ .75 Amps +/- 12V dc @ 1.0 Amps	147 Watts	1500V ac input to output 600V dc output to rack	57C494

**Selection Charts****Model Nos. 57C413, 57C423, 57C431, 57C435, 57C560, 57C570****Processors**

Processor	AutoMax Executive	Max App. Memory	Memory Types	Total Memory	Clock Rate	CPU	Network Programming	Serial Ports	Processors Per Rack	Backplane Current Load	Model Number
6011	Version 2 or Later	300 K, 290 K with AMX V4	Lithium Battery Backed RAM	512 K Note 3	8 MHz	Motorola 68010	Yes	2	4	3A @ 5V dc .1A @ +12V dc .1A @ -12V dc	57C431
7010	Version 2.1J or Later	300 K, 290 K with AMX V4	Lithium Battery Backed RAM	512 K Note 3	25 MHz	Motorola 68020	Yes	2	4	3A @ 5V dc .1A @ +12V dc .1A @ -12V dc	57C435
PC3000 Processor	Version 4.1 or Later	370 K	Lithium Battery Backed RAM	512 K Note 3	25 MHz	Motorola 68040	Yes	2 (Optional)	N/A, Note 1	2.5A @ 5V dc	57C560
PC3000 Packaged Unit	Version 4.1 or Later	370 K	Lithium Battery Backed RAM	512 K Note 3	25 MHz	Motorola 68040	Yes	2	N/A, Note 2	2.5A @ .5V dc	57C570

**Note 1:** Stand-alone version of AutoMax PC3000, plugs into back of PC Chassis**Note 2:** Packaged version of AutoMax PC3000, Industrial PC Chassis (no CPU), Serial Option Board (model no. 57C565) Included**Note 3:** See instruction manuals for memory retention specifications.**Common Memory Module**

Module	Memory	Slot Memory Occupied	Charge Time (Super Cap)	Memory Retention – Battery	Memory Retention – No Battery (Super Cap)	Backplane Current Load	Model Number
Common Memory Module	64 K words Lithium Battery Backed RAM	2 slots (Note 1)	Maximum – 8 minutes	Minimum – 600 Days Typical – 2000 Days	Minimum – 130 Min. Typical – 400 Min.	1.05 A @ 5V dc	57C413
Enhanced Common Memory Module	128 K words Lithium Battery Backed RAM	4 slots (Note 2)	Maximum – 8 minutes	Minimum – 600 Days Typical – 2000 Days	Minimum – 130 Min. Typical – 400 Min.	1.05 A @ 5V dc	57C423

**Note 1:** When used in slot 0, the slot to the right (slot 1) must contain a processor or be empty. When used in an even slot other than 0 (2, 4, 6, etc.), the slot to the right must be empty.**Note 2:** When used in slot 0, the three slots to the right (slots 1, 2, 3) must contain processors or be empty. When used in an even slot other than 0 (2, 4, 6, etc.), the slot to the right must be empty.

**Upgrades****Model Nos. 57C495, 57C496, 57C497****AutoMax Upgrade Program**

Model Number	Description	Replaced By
57C495	Common Memory Upgrade Provides new common memory module with on-board battery in exchange for earlier versions of 57413. Replaced by 57C413.	57C413
57C496	AutoMax 6011 Upgrade Provides new AutoMax 6011 processor in exchange for any version of DCS processor 57407. Replaced by 57C431.	57C413
57C497	AutoMax 7010 Upgrade Provides new AutoMax 7010 processor in exchange for any version of DCS processor 57407 or AutoMax 6010. Replaced by 57C435.	57C413

The AutoMax Upgrade program provides credit to Reliance customers who wish to upgrade their equipment. Customers will be invoiced the normal user price for the equipment ordered and will receive a credit when the exchanged hardware is returned to the Digital Products Service Center (RWO) in good working order. Return authorization paperwork is shipped with the new modules.

DISCONTINUED

**Rack/Chassis Dimensions**

**AutoMax DCS DIMENSIONS**

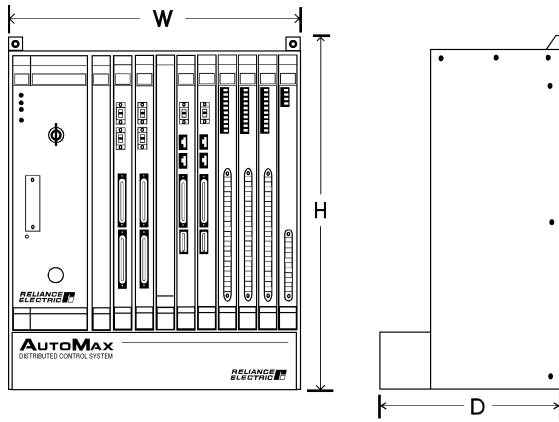

6, 10 and 16 Card Racks

	W inches	H inches	D inches
6-card rack	10 <sup>13</sup> / <sub>16</sub> "	19 <sup>1</sup> / <sub>8</sub> "	12 <sup>1</sup> / <sub>4</sub> "
10-card rack	17 <sup>1</sup> / <sub>4</sub> "	19 <sup>1</sup> / <sub>8</sub> "	12 <sup>1</sup> / <sub>4</sub> "
16-card rack	24 <sup>9</sup> / <sub>16</sub> "	19 <sup>1</sup> / <sub>8</sub> "	12 <sup>1</sup> / <sub>4</sub> "
PC3000 Chassis	6 <sup>1</sup> / <sub>2</sub> "	15 <sup>1</sup> / <sub>2</sub> "	6.7"

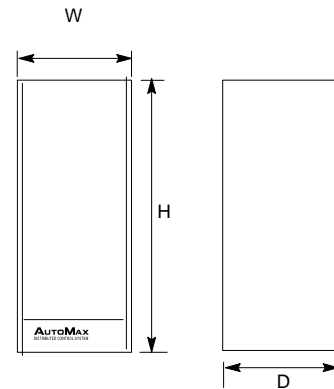

PC3000 Chassis

**System Power Requirements**

M/N	+5V	+12V	-12V	+15V	-15V	Description
57C400	0.425	0	0	0	0	115 VAC Input 16 ch
57C402	0.525	0.045	0.045	0	0	24-115 VAC/D-C Output 16 ch
57C403	1.2	0	0	0	0	115 V High Output - 16 ch
57C404	2.5	0.053	0.0075	0	0	Network Communications
57C407	5	0.1	0.1	0	0	DCS 5000 Processor
57C409	3.05	0	0	0	0	Analog Input - 2 ch
57C410	2.75	0.055	0.055	0	0	Analog Output - 4 ch
57C411	1.7	0.095	0.095	0	0	Resolver Input
57C413	1.05	0	0	0	0	Common Memory - 64K
57C414	2.5	0.053	0.0075	0	0	Modbus Interface Module
57C415	0.625	0	0	0	0	24 VAC/D-C Input - 16 ch
57C416	2.5	0.053	0.0075	0	0	Remote I/O Communications
57C417	2.5	0.053	0.0075	0	0	AutoMate Interface Module
57C418	2.5	0.053	0.0075	0	0	A/B Interface Module
57C419	0.7	0	0	0	0	5-24 VDC Input - 32 ch
57C420	0.85	0	0	0	0	5-24 VDC Output - 32 ch
57C421	0.9	0	0	0	0	Pulse Tach Input Module
57C422	1.6	0	0	0	0	2 Axis Servo Module
57C423	1.05	0	0	0	0	Common Memory - 128K
57C424	2.40	0.053	0.008	0	0	MaxPak III Hi-Speed Link Module
57C428	2.4	0.053	0.008	0	0	Toledo Scale Interface
57C429	2.5	0.03	0	0	0	AutoMax R-Net Processor
57C430	3	0.1	0.1	0	0	AutoMax 6010 Processor
57C431	3	0.1	0.1	0	0	AutoMax 6011 Processor
57C435	3	0.1	0.1	0	0	AutoMax 7010 Processor
57C440	0.5	0.5	0.1	0	0	Ethernet Interface Module
57C441	0.6	0	0	0	0	Modbus Plus Interface
57C442	0.65	0	0	0	0	Data Highway Plus Interface
57C443	0.65	0	0	0	0	A-B Remote I/O Scanner Module
0-57652	1.7	0	0	0.1	0.07	Universal Drive Controller
61C500	1.2	0	0	0	0	115 VAC Input - 16 ch
61C501	1.2	0	0	0	0	115 VAC Input - 16 ch
61C515	1.2	0	0	0	0	24 VAC/D-C Input - 16 ch
61C516	1.2	0	0	0	0	24 VAC/D-C Input - 16 ch
61C540	1.5	0.03	0	0	0	Analog Current Input - 16 ch
61C542	1.5	0.03	0	0	0	Analog Voltage Input - 16 ch
61C544	1.5	0.03	0	0	0	RTD Input - 16 ch
61C605	1.6	0	0	0	0	Thermocouple Input - 8 ch
61C613	1.25	0	0	0	0	Low Level Analog Input - 16 ch
N/A	2.78	0.3	0.22	0.15	0.15	Drive 4-card set

M/N	+5V	+12V	-12V	+15V	-15V	Description
57C493	50	4	4	1	1	Power Supply - 3 slot
57C494	20	1	1	0.75	.075	Power Supply - 2 slot

Note: All power requirements given in amps. Refer to selection table on page 1-8 for PC3000 power requirements.

## Notes

---

**Communications**

---

**Networks and Network Modules**

DCS-NET Communication Network .....	2-2
DCS Network Communications Module .....	2-3
PC Link Interface Module .....	2-5
DCS-Net Fiber Optic Network .....	2-7
A-B Data Highway Plus Module .....	2-8
Remote I/O Communications Module .....	2-10
Remote Input/Output Communications Network .....	2-11
A-B Remote I/O Scanner Module .....	2-12
R-NET Communications Network .....	2-13
R-NET Processor Module .....	2-14

**Interface Modules**

Modbus Interface Module .....	2-15
AutoMate Interface Module .....	2-15
A-B Interface Module .....	2-16
MaxPak III High-Speed Link Module .....	2-16
Toledo Scale Interface Module .....	2-17
Ethernet Interface Module .....	2-17
Multibus ControlNet Module .....	2-18
Modbus Plus Interface Module .....	2-18

**Selection Charts**

Communications Modules .....	2-19
------------------------------	------

## DCS-Net Communication Network

### DCS-Net Distributed Control Network

Control systems have evolved to the point where they make possible real-time distributed control. Some typical applications include paper machines, steel mills and film lines. The need for high performance positioning systems, interlocking systems and distributing the power of the CPU with millisecond response time in a cost-effective means had to be realized.

The DCS-NET, Reliance Electric Distributed Control System network, meets the need. DCS-NET provides a real-time (2.6 msec/node) communication scheme for Distributed Control application.

The network allows 56 AutoMax/DCS nodes to communicate with each other. DCS-NET, a baseband coaxial cable system, is arranged in a multidrop configuration. DCS-NET connects racks up to 3000 feet apart, easily accommodating typical applications within an industrial plant.

Utilizing a master/slave system, the master has complete control of the messages and in turn has a maximum communication time of 2.99 msec/node and a global transmit time of 2.99 msec for register data, no matter how many nodes you have on the network. This Master/Slave system makes DCS-NET a perfect solution for a single-application

distributed control network, due to the real time deterministic communication scheme and the 1.75 M baud. Multiple network cards with multiple masters can also be configured to give you even more power and flexibility.

DCS-NET has the speed that is required to handle process lines, supervisory control and program development-loading/verifying. Both registers, contacts and coils can be used for real-time interlocking.

An IBM-compatible personal computer, through any AutoMax processor or a PC interface card, can be connected to program/monitor any AutoMax/DCS on the network. Even when utilizing multiple network cards with multiple master racks, the programming terminal can transparently communicate from network to network.

Installing the DCS-NET is as simple as plugging a Network communication card into the rack and connecting the network cable to it. The DCS-NET processor handles all network communications, thus freeing the AutoMax processor to perform other tasks. Data transfer between the processors occurs directly over Multibus – not serially. The DCS-NET system is therefore superior to networks utilizing programming ports for serial communications between the controller and the network processor.

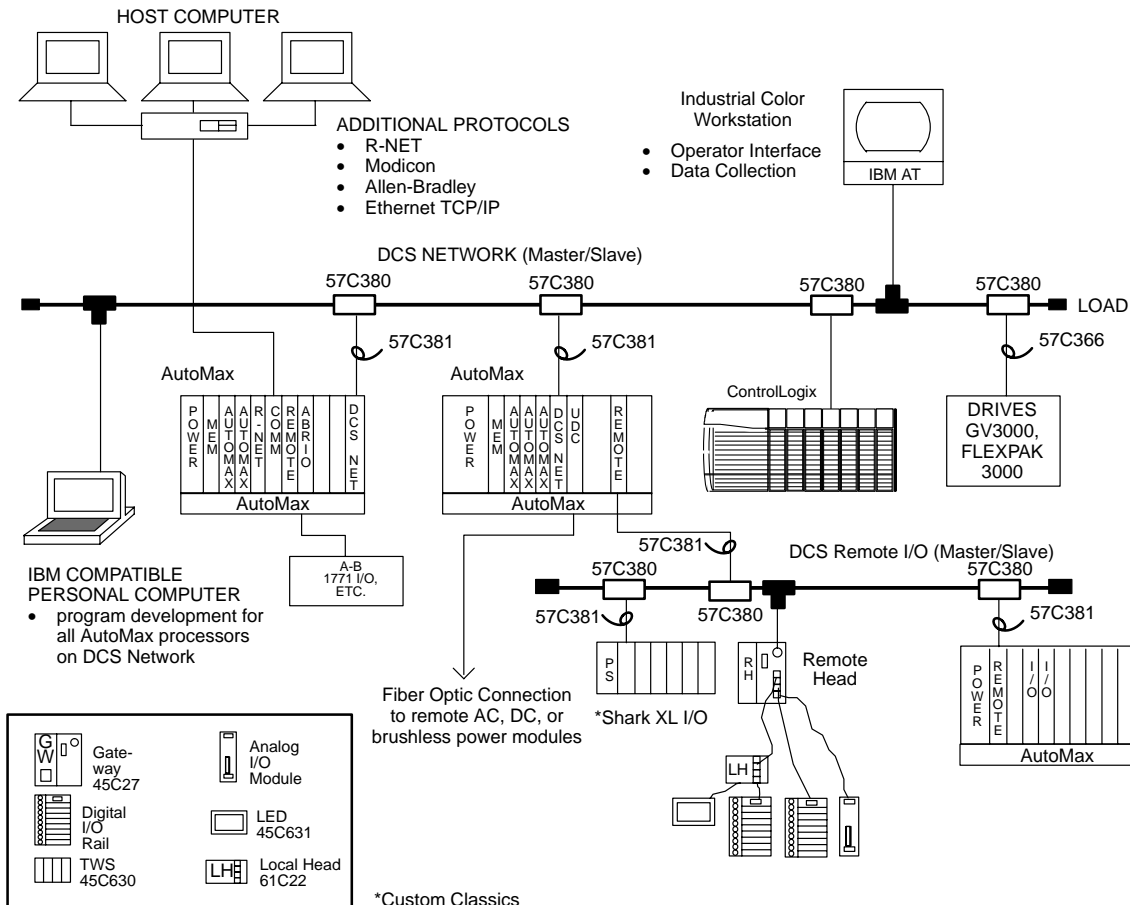



## DCS Network Communications Module

Model No. 57C404



The Network Communications Module provides the necessary hardware required to transmit control and status data between two or more AutoMax Controllers in a network.

The Network Communications Module is a printed circuit assembly with CPU, memory and communications components that plugs into the AutoMax Multibus Rack. The module consists of the printed circuit board, faceplate, and protective enclosure. The faceplate contains the network communications connector, a serial port to monitor module status, a 7-segment diagnostic display, an "OK" LED, and two thumbwheel switches used to set the network node number.

The synchronous network data is transmitted over a Belden #9259 coaxial cable. The connection of the network communications cable to each Network Communications Module on the network is made through the Reliance Passive Tap.

This tap has two fault-isolation resistors in series with the transmission line to prevent a failed Network Communications Module from affecting the remainder of the network.

### Diagnostics

When each Network Communications Module is powered up or the self-test is invoked through the RS-232C port, an internal diagnostic test is performed by the module to check for hardware failures. If an error is encountered, an error code is displayed on the 7-segment LED. Also, during normal operation, if a power, system (backplane) watchdog, or communications line failure occur, an error code is displayed.

### Features

- 875 K BAUD communications rate
- 3000-foot distributed network length
- On-board network diagnostic displays

### LED Status Indicators

- OK – the Network Module is functioning properly
- FAULT CODE – 7-segment LED displays diagnostic error code

### Thumbwheel Switches

- DROP NUMBER – sets the drop number of the Network Module. The master is set 0, subsystems are set 1 to 55.

### Communication Ports

- MONITOR – 25-pin, RS-232 serial for local Network Module status and self-test
- NETWORK – 9-pin for high speed rack-to-rack network communications

### Distributed Control Network

The Reliance AutoMax Distributed Industrial Control Network is a master/slave broadcast configuration. The Master Network Communications Module, defined as "Drop 0", controls all transmissions over the network to the Slave Network Communications Modules, numbered from 1 to 55. The network control and status data are transmitted in packets. Each data packet is transmitted to all active drops on the distributed network. Encoded in each packet is an address which specifies which drop is to respond to the message packet. This continues until all active drops have exchanged data with the master. All messages are checked for correctness by the addressed receiving drop; incorrect messages are retransmitted up to three times. Drops unable to correctly transmit and receive data will go off line. Status information is maintained in each drop and can be interrogated through the serial port on the Network Communications Module or in the user application program.

Each Network Communications Module contains a dual-port memory that can be accessed by its on-board processor as well as over Multibus from the application program on the Processor Module. The dual-port memory contains the data that are transmitted throughout the distributed network. The dual-port memory in each Network Communications Module is partitioned for 56 drops; each drop is assigned 64 16-bit registers (for a total of 3584 registers). Drop 0 registers are used for status and control throughout the Network. To provide for increased register capacity in a Network Module, the Module can be software-configured to function as more than one drop (up to the total network limit of 55).

## DCS Network Communications Module

Model Nos. 57C404, 57C490, 57C498

### V2 Programming

A network definition statement, NETDEF or GBLDEF, is used in the system configuration tasks of each of the drops on the network to define variables as network data. The NETDEF statement assigns a name to the network variable and defines on which network (1 to 15) and drop (0 to 55) the data is located.

Any drop can read information from any other drop on the network simply by specifying the name of the data to be read and the proper drop number in the NETDEF statement. Any reference to the network data within the application program is then made simply by using the defined name.

### Communication Module

Model Number	Description
57C404	DCS-Net Communications Module

### Coaxial Cable System

Model Number	Description
57C380	Communications Passive Tap – Coaxial
57C381	Cable – Communications Module to Passive Tap – 3 Feet
45C70	Coax BNC TEE Connector (2)
45C71	Coax BNC 75 OHM Terminating Load (2)
45C72	Coax BNC Male Connector (5)
45C73	Coax Connector Crimp Tool

The Passive Tap is required at each network or remote drop for connection to the coaxial cabling. All coaxial systems require a terminating load at both ends of the cable. A coax tee is required for a remote I/O head. The 45C72 requires the use of the 45C73 crimp tool.

### Twinaxial Cable System

Model Number	Description
57C366	Cable – AutoMax module to Twinaxial Tap – 3 feet

When Twinax cable is used, an Allen-Bradley 1770-SC Station Connector replaces the 57C380 Passive Tap. A Station Connector is required at each network or remote I/O drop for connecting to the Belden 9463 twinaxial cable. A 150 ohm, 1 watt, terminating resistor is required at each end of the cable network. It is connected across terminals 1 and 3 of the Station Connector.

The 57C366 Drop Cable is used to connect the Station Connector to the AutoMax 57C416 Remote I/O Module or the 57C404 Network Communications Module.

An Amp 555053-1 balun, supplied by others, is used to connect the Station Connector to the 57C328, 57C329 or 57C330 Remote Head.

### AutoMax Upgrade Program

Model Number	Description	Replaced By
57C490	AutoMax Network Module Exchange	N/A
57C498	AutoMax Network Module Upgrade.	57C404

The AutoMax Upgrade program provides credit to Reliance customers who wish to upgrade their equipment. Customers will be invoiced the normal user price for the equipment ordered and will receive a credit when the exchanged hardware is returned to the Digital Products Service Center (RWO) in good working order. Return authorization paperwork is shipped with the new modules.

See page 1-9



**PC Link Interface Module**

**Model No. 57C445**



The AutoMax PC Link Interface Module allows an IBM® computer to function as a drop on the AutoMax DCS-NET and Remote I/O networks. These network connections allow a personal computer to directly exchange data with an AutoMax control system. This high-speed link operates at the AutoMax network transmission speed of 1.75 megabaud, avoiding the bottleneck of RS232 serial connections.

The AutoMax PC Link Interface Module provides an ideal real-time connection between an AutoMax DCS-controlled process and an IBM PC compatible personal computer.

Typical applications include:

- System programming functions
- Data collection
- Statistical process control (SPC/SQC)
- Process monitoring
- Man/machine interface
- Diagnostics
- System start-up and commissioning

The AutoMax PC Link Interface Module is a half-slot (XT) card which plugs directly into the IBM PC XT/AT bus, and provides a direct connection, via rear-mounted coaxial (BNC) connectors to the AutoMax DCS network. No other system connections are required. A maximum of two modules may be used concurrently in the same computer.

**Functional Description**

The AutoMax PC Link Interface module is a microprocessor-based module which is designed to be installed into an IBM XT® or AT® computer. Upon the installation of appropriate interface software, the computer will function as a drop on either the AutoMax DCS-NET or Remote I/O communications networks.

Upon the installation of Network Communication Software (provided) this module becomes functionally similar to the Network Communications Module (M/N 57C404B). In this mode, the AutoMax PC Link Interface Module will function as a valid drop on the network, except as the Master (drop 0), and can be assigned any valid drop depth.

Downloading the Remote I/O Software (provided) to this module will configure it for operation on the AutoMax Remote I/O Network. Once loaded with Remote I/O Software, this module will function like an AutoMax Remote I/O Communications Module. It provides the ability to monitor all drops on the Remote I/O Network, access the output data sent from the master to the slave drops, as well as monitor the data sent to the master by each slave drop.

Using AutoMax programming executive software (V3.3 or later), the user can directly connect an IBM PC through the PC Link module to the DCS Network and perform all on-line programming terminal functions at full network speeds.

Software drivers are available to connect the PC link module to several popular operator interface software packages in the DCS-NET configuration. Reliance will provide a sample software driver and technical assistance to software companies who wish to write drivers for the AutoMax PC link.

**Technical Specifications**

**Ambient Conditions**

Storage Temperature: ..... 40°–85°C  
 Operating Temperature: ..... 5°–50°C  
 Humidity: ..... 5–90% non-condensing

**Communications**

Remote I/O: ..... Master/slave, 1.75 megabaud, 3000 ft total per master communications module, 15 modules per processor rack, and 7 remote racks per module.  
 DCS-Network: ..... Master/slave, 1.75 megabaud, 3000 ft total network, 56 nodes (1 master, 55 slaves).

This module has been discontinued. SST has a module that is a direct replacement. See page 6-4 for more details.

## PC Link Interface Module

Model No. 57C445

### AutoMax PC Link Network Configuration

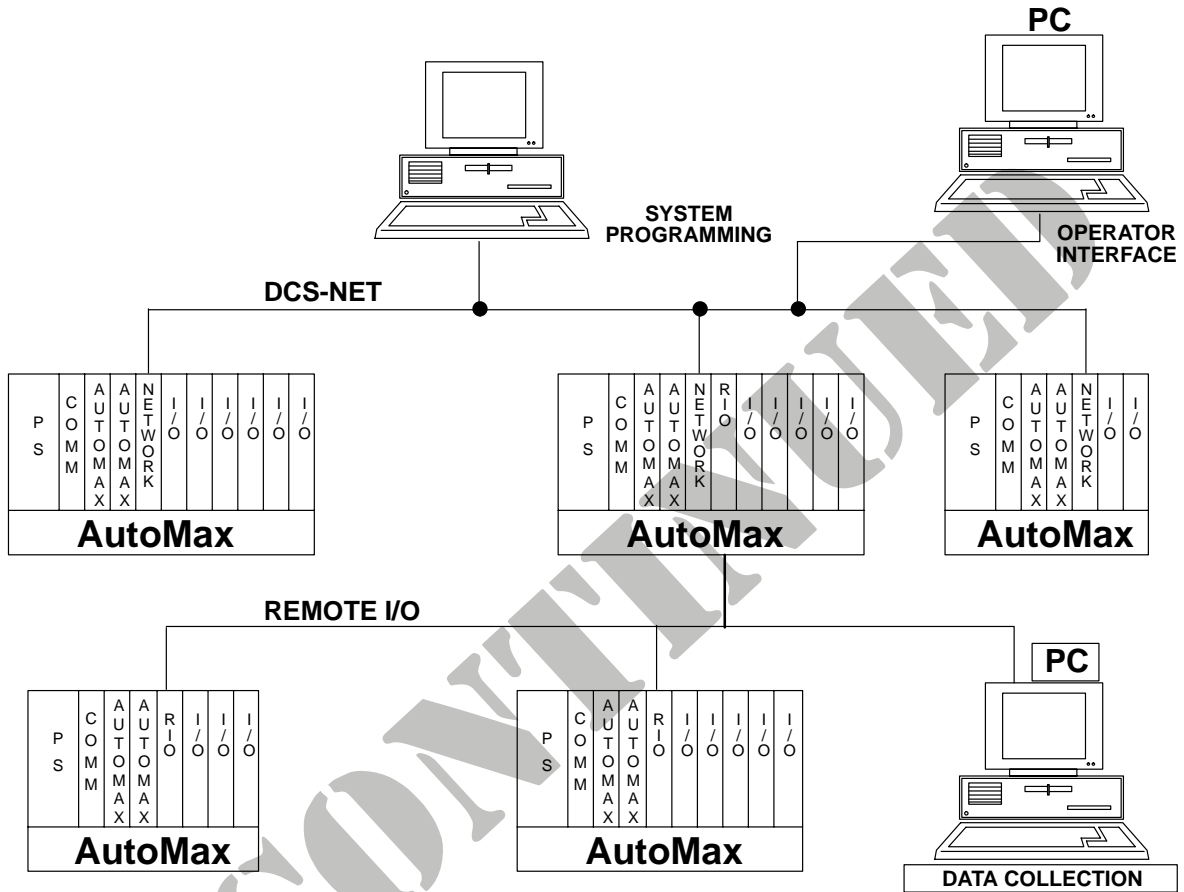

**DCS-Net Fiber-Optic Network**

Model Nos. 57C365, 57C366, 57C367, 57C368

These fiber-optic transceivers have been discontinued from our supplier. Weed Fiber Optic has several products that are a direct replacement.

DISCONTINUED

See page 6-7

**Fiber Optic Cable System**

Model Number	Description	
57C365	Stand-Alone Fiber Optic Transceiver, 24V dc or 14-18 VAC	Discontinued
57C366	Drop cable from AutoMax Module to Fiber Optic Transceiver, 3-feet	Discontinued
57C367	Fiber Optic Transceiver for rack mounting	Discontinued
57C368	Hub Assembly: 10-slot rack with power supply, 115/230 VAC	Discontinued

## A-B Data Highway Plus Network

The Reliance Electric Data Highway Plus Interface Module provides a direct network connection between the Reliance AutoMax Distributed Control System and the Allen-Bradley Data Highway Plus™ Local Area Network. This peer-to-peer network allows each station to communicate to any other station on the network. Up to 64 stations can reside on the network at one time. Typical applications include AutoMax-to-PLC interface, operator interface, supervisory control and data acquisition.

The Data Highway Plus Interface Module contains a dual-port memory image of an Allen-Bradley PLC-5. Messages can be both received and initiated from the card using the standard PLC-5 register and file designations. The GATEWAY\_CMD\_OK@ function in AutoMax Basic is used to initiate messages from the module. The module can be configured using AutoMax Executive Software V3.3F or later.

Physical transmission is through a twisted coax cable (blue hose) terminated on the face of the module. Along with the PLC-5 image registers, the module contains registers for status and control, diagnostics and global register data.

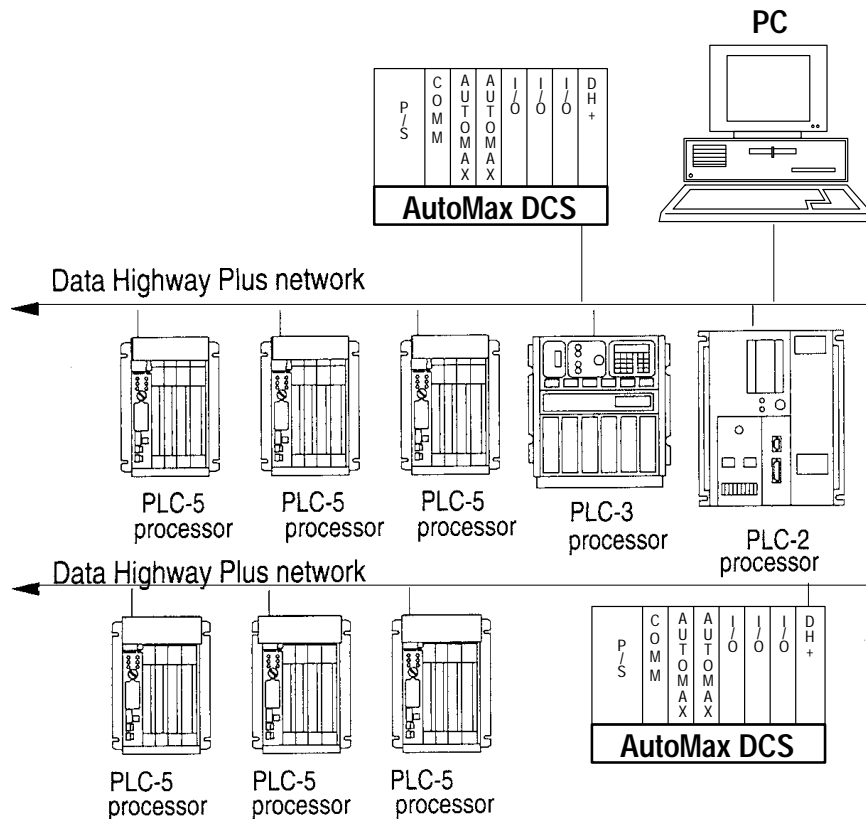

19245

## A-B Data Highway Plus Module

Model No. 57C442



The Data Highway Plus module can reside on the network as any valid octal station number (0–77). The station number is set by two thumbwheel switches on the face of the card and is read by the AutoMax processor upon power up.

The card must be initialized by an AutoMax Basic task in order to configure the correct baud rate and enable global data. The module supports 57.6, 115.2 and 230 Kbaud transmission speeds. The first 64 registers on the module are dedicated to status, control, and diagnostics for serial port transmission errors. The remaining memory on the card is divided into three binary (B3, 4, 5) and twelve integer (N7–N18) file areas with read/write access from both Multibus and Data Highway Plus. When addressing any of the file areas, up to 1000 registers can be accessed in one transaction. The following commands can be initiated by the module:

Command Code	Description
1	Unprotected Read
2	Unprotected Write
3	Word-Range-Read
4	Word-Range-Write
5	Read-Modify-Write

The module will also handle unsolicited messages being generated by other network devices. The following commands are supported this way.

- Typed Read/Read Block
- Typed Write/Write Block
- Diagnostic Counters Reset
- Diagnostic Read
- Diagnostic STATUS
- Protected Bit Write
- Protected Write
- Unprotected Bit Write
- Unprotected Read
- Unprotected Write

The module also supports message transfers between Data Highway Plus networks using intermediate network devices from Data Highway™ or Data Highway II™ when external bridges are used. This is accomplished with the standard variable definitions within the GATEWAY\_CMD\_OK@ function.

Diagnostic registers on the card contain serial transmission errors received at the card from another device. Errors incurred from AutoMax initiated messages are returned in the status% variable in the GATEWAY\_CMD\_OK\_@ function. A memory area has been reserved to allow transmission of network statistic data as well. Statistic and diagnostic counter data are available to any node that requests them.



## Remote Input/Output Communications Network

### Remote I/O Network

The AutoMax Remote I/O Communications Network is a master/slave configuration. The Remote I/O Communications Module functions as the master module when inserted in the Processor Module Rack and as a slave module when in a remote AutoMax rack. One Processor Module can direct a maximum of 15 Master Remote I/O Modules in the master rack and one Master Remote I/O Module can control a maximum of seven remote AutoMax or Shark XL racks or remote heads connected to its remote network.

The Master Remote I/O Communications Module initiates all communications on the remote network, transmitting packets of data addressed to a specific slave drop. The Master Module collects and stores input and output data from all slave modules connected to the remote I/O network. This I/O data is stored in dual-port memory of the master module and is accessible to the Processor Module in the Master Rack as directed by the user's application program.

The Slave Remote I/O Communications Module collects and stores input and output data for a maximum of 15 general purpose I/O modules contained in the same remote AutoMax rack. This data is sent on request to the Master Module.

### V2 Programming

The Remote I/O definition statement (RIODEF) is used in a system configuration task in the Master Processor Module to define any input or output used in a remote rack or remote head on the remote I/O network. The RIODEF statement assigns a name or tag to the I/O point and defines on which network (1 to 15), which drop (1 to 7), and the specific I/O card module in the remote rack that the I/O point is located. Once the I/O point has been so defined, any reference to it anywhere within the AutoMax system is made simply by using its defined name.

### Features

- 875 K baud communications rate
- 3000-foot total remote network length
- Seven remote stations per Remote Communications Module
- 15 Communications Modules per AutoMax Master Rack

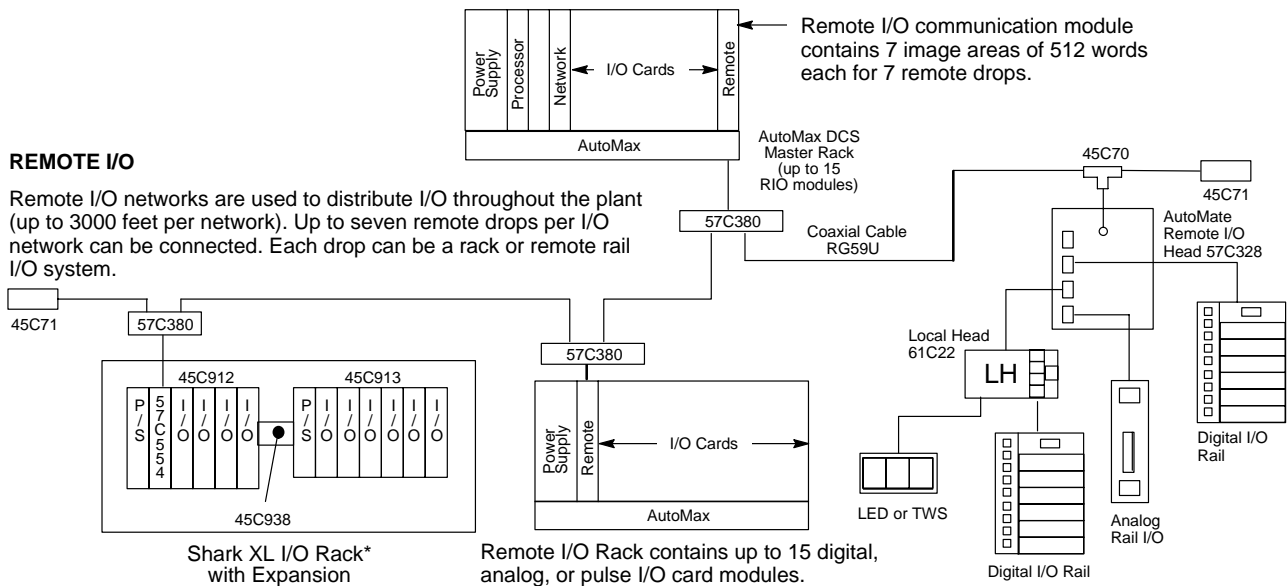

### REMOTE I/O

Remote I/O networks are used to distribute I/O throughout the plant (up to 3000 feet per network). Up to seven remote drops per I/O network can be connected. Each drop can be a rack or remote rail I/O system.

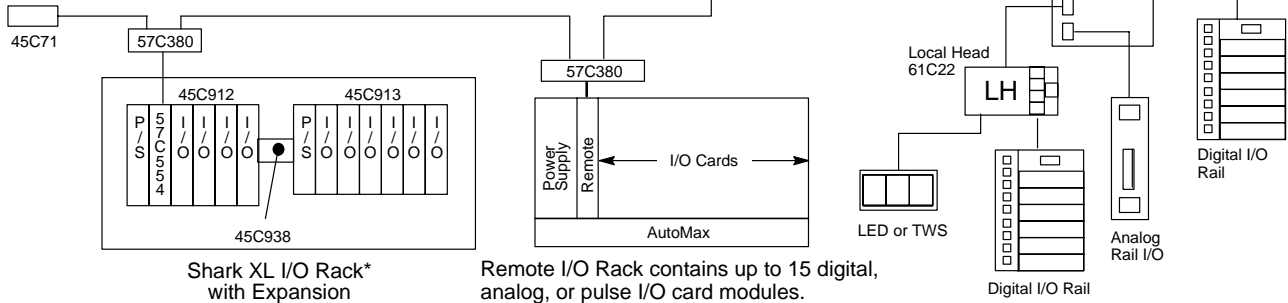

\*Custom Classics



## Remote I/O Communications Module

Model No. 57C416



The Remote I/O Communications Module is the basis for the AutoMax remote I/O system. This Module provides the necessary hardware to allow extended communication and control between the Processor Module Master Rack and remote racks containing general purpose analog and digital I/O card modules and/or remote heads with digital and analog I/O rail modules.

The Remote Communications Module is a printed circuit assembly in a protective enclosure that plugs into the Multibus backplane of the AutoMax Rack. The module has on its faceplate a 7-segment LED for diagnostic displays, an "OK" status light, the remote communications connector, and a serial port to locally monitor or modify I/O status. The remote drop or station number is set using two thumbwheel switches, also on the faceplate.

The remote communications synchronous data is transferred through a Belden 9259 or equivalent coaxial cable. The connection of the coaxial cable to each of the Remote Communications Modules is made through a Reliance Passive Tap which contains two fault-isolation resistors in series with the transmission line. This prevents a failed module from bringing down the entire remote I/O network.

The RS-232C communications port can be used with a serial device to invoke a self-test of the Remote I/O Communications Module, display the status of all parameters associated with the Module and the network, and to locally monitor and modify I/O points on I/O modules within the associated remote rack.

### Diagnostics

When the Remote I/O Communications Module is powered up or a self-test is invoked through the RS-232C port, an internal diagnostics test is executed in the module to check for hardware failures. If an error is encountered, an error code is displayed on the faceplate 7-segment LED. Additionally, during normal operation of the module, if a power failure, system (backplane), or communications line failure occurs, an error code will also be displayed.

### Features

#### LED Status Indicators

- OK – the Remote I/O Module is functioning properly
- FAULT CODE – 7-segment LED displays diagnostic error code

#### Thumbwheel Switches

- DROP NUMBER – sets drop number on the remote network. Master is set 0, remote drops set 1 to 7 on the 2nd switch

#### Communication Ports

- MONITOR – 25-pin, RS-232 serial for network test and status
- NETWORK – 9-pin for network communications



Certifications

## A-B Remote I/O Scanner Module with Adaptor Mode

Model No. 57C443A

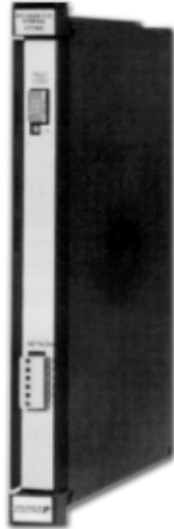

The Allen-Bradley Remote I/O Scanner Module with Adaptor mode can be used as either a scanner or as an adaptor on A-B Remote I/O networks. Adaptor mode functionality was added with the 57C443A release. Modules prior to this release are scanner mode only.

The AutoMax Allen-Bradley Remote I/O Scanner will link AutoMax DCS to devices on the Allen-Bradley Remote I/O network such as Allen-Bradley 1771 I/O, Flex I/O, Block I/O and SLC500 Remote I/O. This functionality further expands your interoperability and aids in simplifying the integration process between the two systems. This card resides in the AutoMax Multibus rack and connects as a scanner to Allen-Bradley Remote I/O devices, thus allowing AutoMax to control devices on the A-B Remote I/O network.

Up to 32 racks of remote I/O may be connected to the Scanner with a selectable baud rate of 57.6K, 115.2K, and 230.4K. For A-B Remote I/O, 1/2, 1, and 2 slot addressing may be utilized. Complementary addressing will not be available. The scanner will be able to communicate to 1/4, 1/2, 3/4, and a full rack. If a partial rack is used, the next rack will begin on the next full rack boundary in the I/O image table. Therefore, any physical Remote I/O Device must be at least 1 logical rack. This module can scan both discrete and analog I/O as well as force inputs and outputs. A maximum of 48 block transfers will be allowed to utilize the transfer of register data.

As an adaptor, the module can communicate with an Allen-Bradley Remote I/O scanner as one or more remote racks. The module can also be configured as any partial rack or a combination of partial racks. The module monitors discrete inputs and outputs on any combination of remote chassis that share its remote I/O link. The module can respond to up to 48 different block transfer read or write requests. However, it does not monitor the block transfers to or from other I/O chassis on the remote I/O link.

Standard Allen-Bradley 1770-CD cable will be used to connect the Remote devices with the scanner card.

The AutoMax System will interface, thru the Scanner Card's Dual Port memory, to the A-B Remote I/O network. The AutoMax Programming Executive has a Graphical User Interface for this card. The card may also be used with AutoMax versions prior to 3.6 if you select the Generic card option for the AutoMax Programming Versions 3.X or by using the IODEF definition statement with AutoMax Versions 2.X or earlier.

The AutoMax System will interface, thru the Scanner Card's Dual Port memory, to the A-B Remote I/O network.

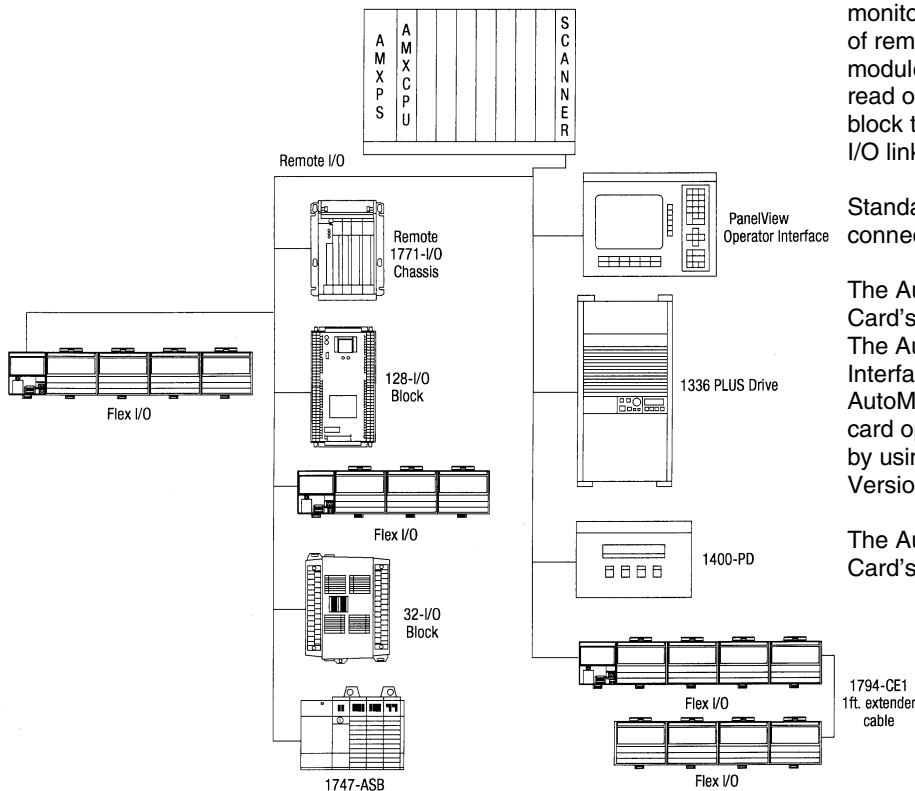



**R-NET Processor Module**

Model No. 57C429



The AutoMax R-NET processor is a single-board interface module to the R-NET Industrial Network, which is commonly employed in Reliance<sup>®</sup> AutoMate<sup>®</sup> PLC systems. It provides a peer-to-peer network connection between AutoMax and AutoMate systems, as well as with host computers and supervisory controllers. One of the main advantages of this topology is the ability of the network to continue communicating if nodes drop off line. Any AutoMax rack with up to four AutoMax processors can support multiple R-NET Processor modules. Multiple R-NET modules in a rack can be on the same or separate network lines.

The AutoMax R-NET processor allows AutoMax users to program tasks using the same RNETDEF variables and commands currently used by the 57C417 AutoMate Interface Module. The AutoMax R-NET Processor provides a BNC connector for direct coax cable connection and high-speed network response. The R-NET processor contains a limited memory image of an AutoMate 40 controller. Up to 2560 registers can be bit- or register-addressed with both read and write functions. The AutoMax DCS rack and its associated processors will have access to the memory image via dual port memory. Global coils are also supported. Global coil status is broadcast to each drop on the R-NET Industrial Network and can be controlled by any drop as well.

Each AutoMax R-NET Processor module contains 16K-bytes of dual-port memory for storing data that are transmitted over the network. The dual-port memory contains an image modeled on a subset of the AutoMate memory area by defining the destination as an AutoMate address. Data is transmitted from the AutoMate image area over the network using a subset of AutoMate communications commands. The dual-port memory can be accessed over the backplane bus by any processor in the rack through application programs.

**Functional Description**

R-NET is a synchronous baseband coaxial cable network system arranged in a multidrop configuration. Network access is granted using a token-passing scheme. Each network node controls the network in turn. When a node has the token, it can transfer data to any or all nodes on the network. When the transaction is completed, the token is passed to the next consecutive node on the network. Data is transmitted over the network via a Belden 9259 or equivalent coaxial cable at a rate of 800 kilobits per second utilizing the AutoMate communications protocol. Up to 32 AutoMate controllers and/or other devices may be connected to the R-NET network. The maximum cable length is 6000 feet using RG-11/U cable.

The AutoMax R-NET Processor module communicates over R-NET using the AutoMate Communications Protocol. A subset of the AutoMate command code is supported to specify what action is to be taken by the AutoMax R-NET Processor Module. These codes are used in BASIC programs and are initiated by executing a GATEWAY\_CMD\_OK@ function. The AutoMax R-NET Processor module can initiate only commands 1 through 4. However, it can respond to all of the commands listed below when initiated by the AutoMate controller:

Octal Code	Command Name	AutoMate Instruction
001	Read Point	
002	Write Point	
003	Read Register	GETRNT
004	Write Register	SNDRNT
013	Read Register List	
014	Write Multiple Points	
050	Who Are You	

All application program data is sent and received by the AutoMax R-NET Processor module's CPU. All handshaking, error-checking, and AutoMate command interpretation is also handled by the AutoMax R-NET Processor module; no additional load is put on the main Processor module(s) for communications.



**AUTOMAX**<sup>®</sup>

DISTRIBUTED CONTROL SYSTEM

**Modbus Interface Module****Model No. 57C414**

The **Modbus Interface Module (57C414)** is used to interface the AutoMax to Modbus-compatible equipment. The Modbus Interface Module has the capability to transform up to four AutoMax Processor Modules in the same chassis into a single Modicon\* 584 look-alike as viewed from the Modbus link. The Modbus Interface Module transfers data between the AutoMax and the Modbus equipment using a subset of the Modbus message function set. Both the RTU (binary) and the Modbus ASCII modes are supported.

**Features****LED Status Indicators**

- OK – the module is functioning properly
- FAULT – 7-segment LED displays status and error codes

**Thumbwheel Switches**

- DROP NUMBER – drop or device number for the appropriate equipment or network

**Communications Port**

- GATEWAY – RS-232 asynchronous link to the non-AutoMax equipment or network

**AutoMate Interface Module****Model No. 57C417**

The **AutoMate Interface Module (57C417)** interfaces the AutoMax to the Reliance Electric AutoMate programmable controller equipment. The RS-232 link may be connected to the R-NET™ Interface Head for access to the R-NET Proprietary Network, to the AutoMate® Serial Communications Card for communicating with one or more AutoMate processors in a rack, or directly to the AutoMate processor itself. The AutoMate Interface Module allows up to four AutoMax Processor Modules to look like a single AutoMate 40E as viewed from the RS-232 communications link. Each AutoMax Processor Module has access to the look-alike AutoMate 40E registers over the AutoMax Multibus backplane. The AutoMate Interface Module

transfers data between the look-alike AutoMate 40E registers and the remote devices using a subset of the AutoMate protocol command messages.

**Features****LED Status Indicators**

- OK – the module is functioning properly
- FAULT – 7-segment LED displays status and error codes

**Thumbwheel Switches**

- DROP NUMBER – drop or device number for the appropriate equipment or network

**Communications Port**

- GATEWAY – RS-232 asynchronous link to the non-AutoMax equipment or network



## A-B Interface Module

Model No. 57C418

---



The **A-B™ Interface Module (57C418)** provides the AutoMax the ability to communicate with Allen-Bradley programmable controller equipment. The A-B Interface Module transfers data between the AutoMax Processor Modules and the Allen-Bradley-related devices using a subset of the A-B protocol. This subset allows the A-B Interface Module to look like a PLC-2, or PLC-3 when viewed from the serial port. The module can act as a master or slave on the A-B Data Highway.

### Features

#### LED Status Indicators

- OK – the module is functioning properly
- FAULT – 7-segment LED displays status and error codes

#### Thumbwheel Switches

- DROP NUMBER – drop or device number for the appropriate equipment or network

#### Communications Port

- GATEWAY – RS-232 asynchronous link to the non-AutoMax equipment or network



## MaxPak III High Speed Link Module

Model No. 57C424

---



The **MaxPak III High-Speed Link Module (57C424)** is designed to reside within an AutoMax DCS system rack, and permits the direct connection of the AutoMax rack to a MaxPak III drive controller. This module provides point-to-point communications fast enough to allow closed loop regulation, and passes control loop, as well as reference and feedback data.

The MaxPak III High-Speed Link Module allows a standard hardware configuration to be applied to many different uses including position and tension regulation.

### Features

#### LED Status Indicators

- OK – the module is functioning properly
- FAULT – 7-segment LED displays status and error codes

#### Thumbwheel Switches

- DROP NUMBER – drop or device number for the appropriate equipment or network

#### Communications Port

- GATEWAY – RS-232 asynchronous link to the non-AutoMax equipment or network

**Toledo Scale Interface Module****Model No. 57C428**

**The Toledo<sup>®</sup> Scale Interface Module (57C428)** provides the AutoMax DCS with weight data from any of the following Toledo Scale Digital Indicators: 8132, 8140, 8142, and 8530. This module is a read only device as seen by the Toledo digital indicator. It uses Toledo Scale standard protocol to read the weight data from the indicator when operated in continuous output mode.

**Features****LED Status Indicators**

- OK – the module is functioning properly
- FAULT – 7-segment LED displays status and error codes

**Thumbwheel Switches**

- DROP NUMBER – drop or device number for the appropriate equipment or network

**Communications Port**

- GATEWAY – RS-232 asynchronous link to the non-AutoMax equipment or network

**Ethernet Interface Module****Model No. 57C440**

**The Ethernet Interface Module (57C440)** allows the direct connection of an AutoMax DCS system to an Ethernet local area network allowing the complete utilization of Ethernet capabilities over thin and thick wire transceivers, as well as fiber optic and broadband modems. Ethernet provides a high speed, industry-standard link between the AutoMax system and other host computers which support Ethernet (IEEE 802.3) and the TCP/IP protocol. The Ethernet Interface Module may be mounted in any rack which contains one or more AutoMax processors. The AutoMax DCS control system will support up to two modules in one rack.

## Multibus ControlNet Module

---

See Section 7-11 for details on the MBCN card.

## Modbus Plus Interface Module

Model No. 57C441

---



### Features

#### LED Status Indicators

- OK – the module is functioning properly
- FAULT – 7-segment LED displays status and error codes

#### Thumbwheel Switches

- DROP NUMBER – drop or device number for the appropriate equipment or network



**The Modbus Plus Interface Module (57C441)** enables the direct connection of an AutoMax DCS system to the Modicon Modbus Plus network. The Modbus Plus network provides peer-to-peer communications at 1 Mbaud with Modicon 984 series programmable controllers, using twisted-pair wire. Up to 32 nodes can operate on the Modbus Plus network at one time. This module may be placed in any slot of an AutoMax rack that contains at least one AutoMax processor, and can communicate with up to four AutoMax processors within the same rack. The AutoMax rack which contains the Modbus Plus Interface module appears as a single station on the Modbus Plus network.



**Selection Chart**

Module	Description	Communication Medium	Transmission Rate	Number Of Drops/Nodes Supported	Backplane Current Load	Model Number
Reliance DCS Network	Provides the necessary hardware to transmit control and status data between 2 or more AutoMax controllers in a network.	RG-59/U Coaxial Cable	875 Kbaud	56 nodes	2.5 A @ 5V dc .053 A @ +12V dc .0075 A @ -12V dc	57C404
Modbus Interface	Interfaces AutoMax to Modbus-compatible equipment. Supports RTU (Binary) and Modbus ASCII modes.	RS-232	1200, 2400, 4800, 9600, or 19200 Baud	1-99 devices	2.5A @ 5V dc .053 A @ +12V dc .0075 A @ -12V dc	57C414
AutoMax Remote I/O Interface	Provides necessary hardware for communication and control between AutoMax Processor Master Rack and remote racks containing general purpose I/O.	RG-59/U Coaxial Cable	875 Kbaud	7 remote racks per module	2.5 A @ 5V dc .053 A @ +12V dc .0075 A @ -12V dc	57C416
AutoMate Interface	Interfaces AutoMax to the Reliance Electric AutoMate PLC equipment.	RS-232	1200, 2400, 4800, 9600, or 19200 Baud	32 nodes	2.5 A @ 5V dc .053 A @ +12V dc .0075 @ -12V dc	57C417
A-B Interface	Interfaces AutoMax to Allen-Bradley programmable controller equipment. Communicates on A-B Data Highway (PLC-2 or PLC-3 modes)	RS-232	1200, 2400, 4800, 9600, or 19200 Baud	64 stations	2.5 A @ 5V dc .053 A @ +12V dc .0075 A @ -12V dc	57C418
Toledo Scale Interface	Provides AutoMax with weight data from the following Toledo Scale Digital Indicators: 8132, 8140, 8142, 8150	Serial, twisted pair, Toledo Scale standard protocol	1200, 2400, 4800, or 9600 Baud	1 device	2.4 A @ 5V dc .053 A @ +12V dc .008 A @ -12V dc	57C428
Reliance R-Net Interface	Interfaces AutoMax to the Reliance Electric R-Net Industrial Network	RG-59/U Coaxial Cable	800 Kbits/sec	32 drops	2.5 A @ 5V dc .030 A @ +12V dc	57C429
Ethernet Interface	<b>DISCONTINUED</b>					
Modbus Plus Interface	Interfaces AutoMax DCS systems to the Modicon Modbus Plus network.	Belden 9841 shielded twisted pair cable	1.0 Mbits/sec	32 devices	.60 A @ 5V dc	57C441
A-B Data Highway Plus Interface	Interfaces AutoMax DCS systems to the Allen-Bradley Data Highway Plus network.	Belden 9463 twin-axial cable (Allen-Bradley 1770-CD)	57.6 Kbps @ 10000 ft. 115.2 Kbps @ 5000 ft. 230.4 Kbps @ 2500 ft.	64 stations	.65 A @ 5V dc	57C442
A-B Remote I/O Scanner with Adaptor mode	Interfaces AutoMax DCS systems to devices on the Allen-Bradley Remote I/O network.	Belden 9463 twin-axial cable (Allen-Bradley 1770-CD)	57.6 Kbps @ 10000 ft. 115.2 Kbps @ 5000 ft. 230.4 Kbps @ 2500 ft.	32 racks	65 A @ 5V dc	57C443A
Reliance DCS Network Exchange	Provides re-manufactured network module (M/N 57C404) in exchange for any version of the network card.	RG-59/U Coaxial Cable	875 Kbaud	56 nodes	2.5 A @ 5V dc .053 A @ +12 Vdc .0075 A @ -12 Vdc	57C490
Reliance DCS Network Upgrade	<b>DISCONTINUED</b>					
ControlLogix DCSNet	Migration connectivity between ControlLogix and AutoMax (DCSNet or Remote I/O)	MBCN 64 connection ControlNet tap and cable	875 Kbaud	56 nodes	N/A	56AMXN LDS*
MBCN	Multibus ControlNet for AutoMax	ControlNet tap and cable	5 Mbits/sec	64 connection	.35 A @ 5 Vdc	58820-1 LDS*

\*Legacy Drive Systems

## Notes

---

**AutoMax I/O Systems**

Local I/O .....	3-3
Remote I/O .....	3-3
Multibus I/O .....	3-3
Rail I/O .....	3-3
Allen-Bradley IO .....	3-3

**Multibus I/O System**

Digital Input Modules .....	3-4
Digital Output Modules .....	3-4
Analog Input Modules .....	3-5
Analog Output Modules .....	3-10
Specialty I/O Modules .....	3-11
Resolvers .....	3-11

**Rail I/O System**

57C328 Remote Head .....	3-18
61C22 Local Head .....	3-18
45C1 Digital Rail .....	3-19
Digital Input Modules .....	3-19
Digital Output Modules .....	3-19
Analog Rail I/O Modules .....	3-19
45C630 Thumbwheel Switch Interface Module .....	3-20
45C631 LED Interface Module .....	3-20

**Selection Charts**

Multibus Digital Input Modules .....	3-21
Multibus Digital Output Modules .....	3-21
Multibus Analog Input Modules .....	3-21
Multibus Analog Output Modules .....	3-21
Multibus Specialty Modules .....	3-22
AutoMax Remote Head .....	3-22
Local Heads .....	3-22
Digital Rails .....	3-22
Rail I/O Digital Input Modules .....	3-22

## Input/Output System

---

Rail I/O Digital Output Modules .....	3-24
Rail Analog Input and Output Modules .....	3-25
Rail Specialty I/O Modules .....	3-25
Dimensions .....	3-26
 <b>Connection Diagrams</b>	
Multibus Digital Input Modules .....	3-27
Multibus Digital Output Modules .....	3-28
Multibus Analog Input Modules .....	3-29
Multibus Analog Output Modules .....	3-30
Multibus Specialty Modules .....	3-30
Rail I/O Digital Input Modules .....	3-33
Rail I/O Digital Output Modules .....	3-33
Rail Analog Input Modules .....	3-35
Rail Analog Output Modules .....	3-35
Rail Analog Input/Output Modules .....	3-35
 <b>Allen-Bradley I/O System</b>	
Introduction .....	3-36
AutoMax Connectivity .....	3-36

The AutoMax product family supports a number of different Rockwell Automation Family I/O systems. I/O can be configured as either “local” or “remote” for the Multibus based AutoMax or “remote” only for the PC3000 based AutoMax.

### Local I/O

This is I/O which is physically located in the same card rack as the AutoMax processor. Local I/O communicates with the processor over the rack backplane. For AutoMax, the only local I/O supported is Multibus I/O. The AutoMax PC3000 does not support local I/O.

### Remote I/O

This is I/O which communicates with the AutoMax processor over a remote I/O communications network. The network operates in a “master-slave” environment with the network interface device located in the same rack as the processor being the master and all other network devices that it talks to being slaves. Remote I/O supported by AutoMax includes Multibus based I/O, Rail I/O, Allen-Bradley I/O and the “Custom Classic” Shark XL I/O systems. Multibus based AutoMax’s can have more than one remote I/O network installed and operating.

The I/O families supported by AutoMax include:

- Multibus based I/O
- Rail I/O
- Allen-Bradley I/O
- Custom Classic (Shark XL) I/O

### Multibus I/O

This I/O family is used as either local or remote I/O devices in AutoMax rack based systems using the 57C431 or 57C435 processors.

When used as remote I/O devices, a 57C416 Remote I/O Communications Module must be used in the rack (master) containing the AutoMax processor and in all remote (slave) I/O racks.

### Rail I/O

The Rail I/O family is only used as remote I/O for the Multibus based AutoMax. It requires that a 57C416 Remote I/O Communications module (master) be used in the rack containing the AutoMax processor and one or more (slave) 57C328 Remote Heads be installed in the field. Each 57C328 Remote Head can support up to 256 digital inputs or outputs or up to 16 analog inputs or outputs.

Rail I/O can also be used with the AutoMax PC3000 family of drive controllers. It requires that the 57C328 Remote Head be replaced with the Allen-Bradley Remote I/O Head. Again the Remote Head will support up to 256 digital inputs or outputs and up to 16 analog inputs or outputs.

### Allen-Bradley Remote I/O Devices

Allen-Bradley I/O devices can be used with either the Multibus rack based AutoMax systems or with the AutoMax PC3000 family.

When used with the Multibus rack based AutoMax family, the 57C443 A-B Remote I/O Scanner module is required in the AutoMax rack containing the AutoMax processor(s) as the network master.

The AutoMax PC3000 family comes with a built-in A-B remote I/O scanner interface. It supports up to 32 I/O drops of A-B I/O devices.

## Multibus I/O System

Model No. 57C402, 57C403, 57C419, 61C501, 61C516

### AutoMax Digital I/O Card Modules

#### Inputs

##### 16 Points

61C501-115 VAC/DC Input Module

61C516-12 V to 24 VAC/DC Input Module

- 16-point high-density digital I/O
- 2500 V isolation
- Isolated commons (groups of four)
- LED indicator for each point
- Keyed connectors

##### 32 Points

57C419-5 V to 24 VDC Input Module

- 32-point high-density digital I/O
- 5000 V isolation
- Isolated commons (groups of four)
- LED indicator for each point
- Four input interrupt channels

#### Outputs

57C402-24 V to 115 VAC/DC Output Module

57C403-115 VAC High Output Module

- 16-point high-density digital I/O
- 2500 V isolation
- Isolated commons (groups of four)
- LED indicator for each point
- Keyed connectors

57C402-5 V to 24 VDC Output Module

- 32-point high-density digital I/O
- 5000 V isolation
- Isolated commons (groups of four)
- LED indicator for each point
- Four input interrupt channels

The Digital I/O Card Modules provide inputs from discrete ON/OFF devices such as pushbuttons, selector switches and limit switches, or produce ON/OFF output signals to indicators, motor starters, solenoids and other control equipment.

Each of the Digital I/O Card Modules consists of a printed circuit board, a faceplate and a protective enclosure. The faceplate contains an LED status indicator for each input or output point and a female connector socket.



Inputs are brought into and out of the modules via a multi-conductor cable having a plug that mates with the faceplate socket. At the other end of the cable is a group of stake-on connectors that attach to a terminal board for field wiring. The LED indicators are arranged in the same order as the input or output terminals on the connector socket. Each LED turns on when a voltage is applied to the respective input or output. The faceplate connector socket and cable plug have provisions for keying each cable to its respective module to prevent reinsertion of the cable into the incorrect module.



#### V2 Programming

The 16-point modules each contain 16 bits of addressable data which correspond to the 16 input or output points on the Module. In normal usage, each bit is assigned a Boolean variable name in the System Configuration Task using the IODEF (I/O definition) or RIODEF (remote I/O definition) statements.

IODEF name [SLOT=x,  
REGISTER=y,  
BIT=z]

RIODEF name [SLOT=v,  
DROP=w,  
SLOT=x,  
REGISTER=y,  
BIT=z]

The I/O point variable is identified by its module slot number (0 to 15), its register number (always 0 for digital I/O) and the bit or point number (0 to 15). If the module is in a remote rack, the variable is also identified by the slot in the Master Rack of the Remote I/O Communications Module (0 to 15) and the Remote Rack drop number (1 through 7). The 32-point Modules contain 32 bits of addressable data stored in 2 registers (registers 0 and 1) and are configured the same. Once defined in the Configuration Task, the digital I/O point is referred to simply by its variable name in the BASIC, Control Block, and Ladder Logic tasks.

**Multibus I/O System****Model No. 57C409****Analog Input Module**

- Two input channels
- $\pm 1, 5, 10, 20$  V input ranges
- 4 to 20 mA current input range
- 500 V isolation input to logic
- 12-bit resolution plus polarity
- Software-selectable input filtering
- Software-selectable sampling rates
- Program-interrupt capability

**Conversion Performance**(values given in % full scale,  $\pm 1/2$  bit)

- Nominal Absolute Accuracy:  $\pm 10,000$  V  $\pm 2\%$  =  $\pm 4095$
- Repeatability: 1 LSB = .25%
- Linearity:  $\pm .025\%$
- Thermal Drift: .015% per degree C
- Offset: +79 mv to -55 mv max.
- Update Period: 500 microseconds to 32 sec.

The Analog Input Module provides variable reference and feedback signals for high-performance closed-loop control. The module consists of a printed circuit assembly, protective enclosure and faceplate. The faceplate contains a female connector socket through which external analog signals are input via a multi-conductor cable with attached terminal strip. The mating cable plug and faceplate socket are keyed to prevent insertion of the cable plug into the incorrect module. Also on the faceplate are four diagnostic LED displays.

Full scale resolution is  $\pm 4095$ . Resistors are provided on board for standard inputs of  $\pm 10$  Volts or  $\pm 1$  Volt full scale; other inputs are accommodated by connecting specified resistors to the terminal strip. 100% over-range conversion allows the detection in application software of abnormal signal levels. Four low pass filters are software-selectable to reduce signal noise and also provide anti-aliasing for high frequency signals. Sample-and-hold circuits maintain constant input values during the successive approximation analog to digital conversion.

**V2 Programming**

The Analog Input Module contains eleven 16-bit registers of data. Registers 0 and 1 contain the Channel 1 and Channel 2 converted analog to digital data. The remaining registers are used to select update times, interrupt functions and other filter characteristics if required.

The correspondence between the actual analog input and the converted digital value in the register is:

<u>voltage in (selectable)</u>		<u>digital</u>
+1 V	+10 V	+4095
0 V	0 V	0
-1 V	-10 V	-4095

In normal use, each analog input channel is assigned an integer variable name in the System Configuration Task using the IODEF or RIODEF I/O definition statements.

```
IODEF BATCH_TEMP%
      [SLOT=7,
      REGISTER=1]
```

Once defined, each analog input signal is referred to by its variable name in any of the application program tasks. The Analog Input Module can also generate an interrupt to the Processor Module for use with the EVENT statement if programmed to do so.

Using the AutoMax Programming Package, the digital value associated with each analog input channel can be monitored.

## Multibus I/O System

### Model No. 61C613

---

Due to suppliers discontinuing the manufacturing of custom chips, the 61C613 Analog/Thermocouple Input module, the 61C614 Thermocouple/Analog Termination Panel and the 61C605 Thermocouple Input module will no longer be manufactured.

It is unfortunate that these custom components are no longer available, but there are options that will allow the AutoMax to continue to deliver the exceptional performance it has come to stand for.

**Option 1:**

Rockwell Automation will continue to support repairs as long as components are available. If you require repair for one of these products, contact Rockwell Automation Repair at 1-800-669-6119 or 740-548-5733.

**Option 2:**

Replace the card with an Allen-Bradley I/O card from the 1771, 1746 or 1794 Flex I/O families that provides similar functionality. Some engineering will be required to add the replacement I/O to a new or existing network, rewire the data points, modify the AutoMax application software and to adjust for offsets.

**Option 3:**

If you only have a small number of points that require being monitored, you may choose to replace the obsolete module using a standard analog input card and analog signal converters. Some engineering will be required to specify the converter and reconfigure the rack for the analog card. An adjustment for range and offset will be required.

For assistance in implementing options 2 or 3, please contact your Rockwell Automation Local Drive Solution Center (see pages 7-7).



**Multibus I/O System****Model No. 61C614**

---

Due to suppliers discontinuing the manufacturing of custom chips, the 61C613 Analog/Thermocouple Input module, the 61C614 Thermocouple/Analog Termination Panel and the 61C605 Thermocouple Input module will no longer be manufactured.

It is unfortunate that these custom components are no longer available, but there are options that will allow the AutoMax to continue to deliver the exceptional performance it has come to stand for.

**Option 1:**

Rockwell Automation will continue to support repairs as long as components are available. If you require repair for one of these products, contact Rockwell Automation Repair at 1-800-669-6119 or 740-548-5733.

**Option 2:**

Replace the card with an Allen-Bradley I/O card from the 1771, 1746 or 1794 Flex I/O families that provides similar functionality. Some engineering will be required to add the replacement I/O to a new or existing network, rewire the data points, modify the AutoMax application software and to adjust for offsets.

**Option 3:**

If you only have a small number of points that require being monitored, you may choose to replace the obsolete module using a standard analog input card and analog signal converters. Some engineering will be required to specify the converter and reconfigure the rack for the analog card. An adjustment for range and offset will be required.

For assistance in implementing options 2 or 3, please contact your Rockwell Automation Local Drive Solution Center (see pages 7-7).

**Multibus I/O System****Model No. Current 61C540, Voltage 61C542****16-Channel Analog Input Modules**

- 16 channels of either voltage or current input
- Broken wire detection
- Running average 1–60 samples
- Square root extraction
- Scaled or unscaled
- 4 alarm set points per channel (low low, low, high, high high)
- 12-bit resolution plus sign
- Automatic calibration

The Analog Input module provides 16 channels of analog input for either 4–20mA or +/- 10V VDC input signals.

Analog inputs are wired to a separate termination panel (DIN rail or flat panel mounted). The termination panel communicates over a five foot cable to the Multibus<sup>®</sup> input module. Cables are supplied with termination panels. All 16 channels of analog input can be accommodated on a single termination panel.

These modules can be mounted in either local or remote racks. An external power supply is required to supply the 4–20mA transmitters on the current input card.

Each channel consists of a pair of high impedance measurement inputs. The sixteen inputs share the same common. The sixteen pairs of inputs are multiplexed to an instrumentation amplifier which drives an A/D converter.

The data register of a configured channel is updated when the on-board processor converts and averages together approximately 166 samples (60 Hz) or 200 samples (50 Hz) of the channel input. In this manner, line frequency noise at the input of the A/D converter is integrated out of the result that is provided to the system. This provides an update time of 27 msec per channel (31 msec at 50 Hz). The line frequency filter can be disabled on a per channel basis for a faster response time. This allows for updates of 2 msec per channel unscaled.

The module also contains three voltage references for A/D converter calibration. These references are checked at the end of each scan of the configured channels and the calibration coefficients are updated accordingly. No potentiometer adjustments are required to maintain the specified accuracy.

**Certifications****Specifications****Channels**

- Number of input channels: 16
- Commons: one analog common shared by 16 input channels
- Isolation: 2500V from analog common to digital ground

**Input Circuit**

- Resolution: 4  $\mu$ A per count
- Accuracy: 0.2% across the operating temperature range
- Input Filter: first order, lowpass, 7 Hz breakpoint
- Input Overvoltage Protection: 115 V (rms) continuous
- Input Impedance:
  - 1000M ohms typical at 0 Hz at faceplate connector
  - 250 ohms with Terminal Board M/N 61C549 or 61C550 attached

**Noise Rejection**

- Line Frequency Filter (Software Selectable) 60 Hz (default) or 50 Hz
- Averaging Filter (Software Selectable): 1 (default) to 60 samples per average
- Common Mode Rejection: –60dB min (averaging filter disabled and line filter enabled)
- Normal Mode Rejection: –40dB min (averaging filter disabled and line filter enabled)

**Timing With Line Frequency Filter Enabled**

- Update Time per Channel:
  - 27.5 msec at 60 Hz (worst case)
  - 31.5 msec at 50 Hz
- Channel Scan Time with 16 Channels Configured and 2 Reference Channels per Scan (worst case):
  - 365 msec at 60 Hz
  - 429 msec at 50 Hz
- Integration Period (60 Hz): 16.67 msec per conversion per channel (50 Hz): 20.00 msec per conversion per channel

**Timing with Line Frequency Filter Disabled**

- Update Time per Channel (worst case):
  - 2.5 msec/channel unscaled
  - 3 msec/channel scaled
  - 5 msec/channel sq. rt.
- Channel Scan Time with 16 Channels Configured and 2 Reference Channels per Scan (worst case):
  - 45 msec unscaled
  - 53 msec scaled
  - 85 msec sq. rt.

**Multibus I/O System**

Model No. 61C549, 61C550, 61C547, 61C548

**Analog Input Module Related Components**

**M/N 61C549 Panel Mount Terminal Board and Cable Assembly for 61C540**

The terminal board assembly provides terminals on a flat panel mounting surface for connecting the field wires coming from the transmitters. Also included is a cable to connect the terminals with the Current Input module. The cable is five feet long. One assembly is required per module.

**M/N 61C550 DIN Rail Mount Terminal Board and Cable Assembly for 61C540**

The terminal board assembly provides terminals on a DIN rail mounting surface for connecting the field wires coming from the transmitters. Also included is a cable to connect the terminals with the Current Input module. The cable is five feet long. One assembly is required per module.

**M/N 61C547 Panel Mount Terminal Board and Cable Assembly for 61C542**

The panel mount terminal board assembly provides terminals on a flat panel mounting surface for connecting the field wires coming from the transmitters. Also included is a cable to connect the terminals to the Voltage Input module. The cable is five feet long. One assembly is required per module.

**M/N 61C548 DIN Rail Mount Terminal Board and Cable Assembly for 61C542**

The DIN rail terminal board assembly provides terminals on a DIN rail mounting surface for connecting the field wires coming from the transmitters. Also included is a cable to connect the terminals to the Voltage Input module. The cable is five feet long. One assembly is required per module.

M/N 61C549 Terminal Board and Cable Assembly  
(M/N 61C550 is similar)

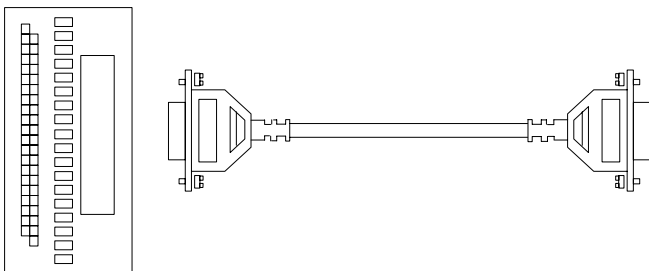

M/N 61C547 Terminal Board and Cable Assembly  
(M/N 61C548 is similar)

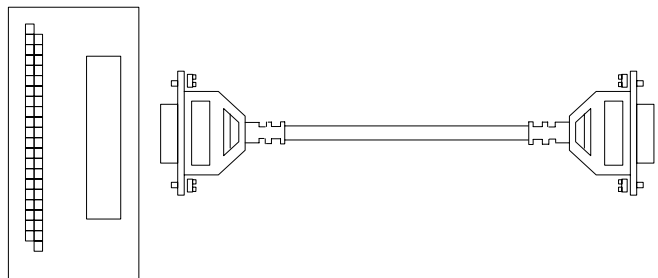

**PANEL-MOUNT TERMINAL BOARD M/N 61C549, 61C547**

Hole Size: 0.27" x 0.20" Oval  
0.68 cm x 0.50 cm

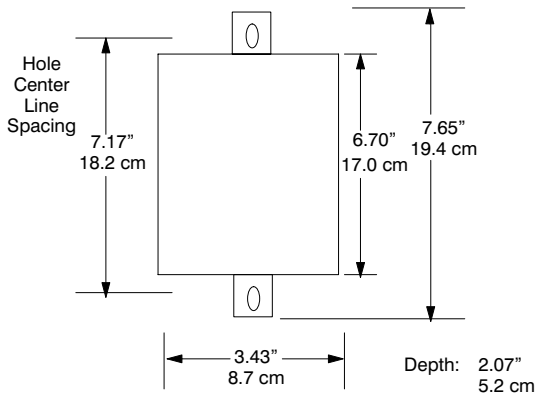

**DIN RAIL-MOUNT TERMINAL BOARD M/N 61C550, 61C548**

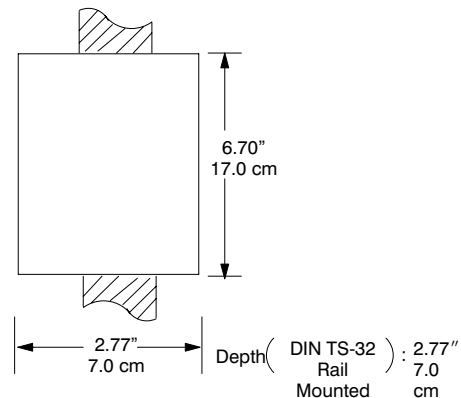

**Multibus I/O System**

**Model No. 57C410**

**Isolated Analog Output Module**

- Four analog output channels
- Selectable voltage or current output
- 2500 V isolation, logic-to-channel and channel-to-channel
- 12-Bit D/A resolution

**Specifications**

- Analog Outputs: Four
- Output Range:  
Voltage:  $\pm 5$  V,  $\pm 8$  V,  $\pm 10$  V (maximum 10 mA output)  
Current: 4 to 20 mA (external power required)
- Common: Four channels individually isolated
- Isolation Voltage: 2500 VAC rms, logic-to-channel and channel-to-channel
- Resolution: 12 bits plus polarity
- Accuracy: (0 to 60 deg. C)  
Voltage:  $\pm 0.10\%$  full scale  
Current:  $\pm 0.15\%$  full scale
- Output Filter: 100 Hz first order lowpass



**LED Indicators**

- ISOL POWER0
- ISOL POWER1
- ISOL POWER2
- ISOL POWER3  
–indicates the power status of each output channel.

The Analog Output Module provides multichannel variable output signals for loop control, process indication and recording. The 4-channel Output Module with digital-to-analog-output-channel isolation and output-channel-to-output-channel isolation is a printed circuit assembly with protective enclosure and faceplate that plugs into the AutoMax Multibus Master and Remote Racks. The faceplate of the module contains four LED indicators and a 20-pin connector socket. Each LED indicator shows the isolated power status for each of the analog output channels. The analog signals are output through a multi-conductor cable and termination strip which plugs into the keyed connector socket.

For each analog output channel, the output voltage range is selected by proper external jumpering of the 20-pin connector. Current output signals require an external supply to power the control loop. Both analog voltage and current signals are available per channel (simultaneously if desired).



**Programming**

The Analog Output Module contains four 16-bit registers of data, one for each output channel. The correspondence between the integer value in the register and the actual analog output is:

Digital	voltage out (selectable)			current out
4095	+5 V	+8 V	+10 V	20 mA
0	0 V	0 V	0 V	4 mA
-4095	-5 V	-8 V	-10 V	0 mA

A single integer IODEF or RIODEF statement is used to define each analog output channel. For example, the Configuration Task statement:

```
IODEF SPEED %[SLOT=5,
REGISTER=1]
```

causes the integer variable SPEED% to be assigned to Channel 1 of the Analog Output Module in Slot 5 of the Master Rack. Once defined, each analog output is referred to simply by its assigned name in any of the application program tasks.

Using the DS 5000 Programming Package, the digital value associated with each analog channel can be monitored. An external voltage or current meter can be used to measure the actual signal output to determine if the Module is operating correctly. In addition, the four LED's on the faceplate indicate the status of the internal isolated power for each channel.

**Multibus I/O System****Model No. 57C411****Resolver Input Module**

- 12-bit position feedback signal
- 2-bit revolution counter (four revolutions)
- Selectable sampling interval from 500 microseconds to 32 seconds
- External strobe input available for position data sampling

**Specifications**

Reference Output Signal: 26 V rms, 2381 Hz sine wave

Rated Load: 400 ohm @ 2381 Hz

Resolver Input: 11.8 V rms resolver format sine and cosine; 26 V rms reference return

Input Isolation: 500 V input to logic

**LED Status Indicators**

- DIRECTION – resolver direction
- FDBK OK – resolver input signal OK
- CCLK OK – backplane control signal OK
- IPS OK – the on-board isolated power supply is functioning
- OK – the Resolver Module is functioning properly within the limits of the internal diagnostics

The Resolver Input Module converts the angular displacement of a resolver into a digital value for use by the AutoMax in position feedback, speed and direction measurement applications.

The Module plugs into the AutoMax Multibus Rack and consists of a printed circuit assembly, protective enclosure and faceplate. The faceplate contains a 10-pin socket connector and five LED indicators.

The Resolver Input Module is an interrupting control card which regulates the acquisition of position data from a resolver. The module produces a sine wave reference output voltage to drive the resolver and accepts as input a reference voltage and sine and cosine position signals. Position data is acquired from the resolver in one of two ways: through an external strobe input or when a software programmable scan timer “times out”.

**EXTERNAL STROBE** – The external strobe input gives an application task the capability of capturing position data concurrent with the occurrence of an external event, such as the material on a conveyor line reaching a specified mark.

**SCAN TIMER** – Resolver data can also be obtained at specified time intervals using the internal scan timer. The period of the interrupt and, thus, the resolver sampling time, are programmable under software control by writing to the on-board Timer Register. The sampling of the resolver rotor position can be programmed in intervals from 500 microseconds to 32 seconds.

**Certifications****Programming**

The resolver inputs are converted on the module to a 12-bit absolute position to which is added a two-bit revolution count. The Resolver Input Module has five data registers which are accessible to the AutoMax application program tasks.

**Resolver****Model Nos. 57C360 & 57C361**

A resolver, interfacing with the Resolver Input Module (57C411), provides absolute position and velocity feedback information to the AutoMax Distributed Control System. The Resolver may also be connected to the Resolver and Drive I/O Module in Distributed Power Systems. Resolvers consist of a rotor and a stator. The single-winding rotor revolves inside a fixed stator. The stator has two windings mechanically displaced 90 degrees.

**Features:**

- Accuracy: maximum error spread of 5 minutes @3000 Hz
- Transformer-coupled rotor (brushless operation)
- Output at zero speed provides excellent diagnostic capability
- Standard duty housing and shaft. Includes connector (57C361)
- Heavy duty housing with Nema 56C– Face or foot mounting and 5/8” dia. shaft: (57C360)

## Multibus I/O System

Model No. 57C421

---

### Pulse Tach Input Module

- 100 kHz maximum input frequency
- 24-bit counter and comparator
- 500 V rms isolation
- 2 kHz internal timer
- Six status LEDs
- No on-board jumpers

### Specifications

- Counter: 1-channel, 24-bit, sign extended to 32-bit
- Input Pulses: 3-channel (phase A, phase B, Z-pulse)
- Maximum Input Frequency: 100 kHz
- Input Voltage: 5 V to 12 VDC
- Isolation: 5000 VAC rms, input-to-logic and input-to-input
- Internal Timer: 16-bit, 2 kHz
- Comparator: 24-bit, compare equal-to, greater-than, less-than contents of 24-bit counter



The Pulse Tach Input Module interfaces a pulse tachometer with the AutoMax System for tracking and speed measurement applications. The Module is a printed circuit assembly with protective covers that plugs into the Multibus backplane of the AutoMax Rack. The faceplate of the module has a 20-pin connector socket and six LED displays. The mating plug of the supplied multiconductor cable/terminal strip can be keyed to the module connector socket.

Pulse Tach Module inputs include the two 90-degree phase-shifted pulse tach signals and external latch, count stop, and origin/clear inputs. A Z-pulse input signal can be used to detect zero position. Interrupts can be generated for the external latch, count stop, origin inputs and the internal comparator equal signal.

### LED Indicators

- CCLK OK – the common clock signal is being supplied
- REVERSE – receiving reverse pulses
- FORWARD – receiving forward pulses
- LATCH – the external latch signal is present
- CLEAR – the external clear/origin signal is present
- COUNT STOP – the external count stop signal is present



### Programming

The Pulse Tach Input Module has eight registers which are accessible by the AutoMax application program tasks.

Registers 0 & 1: 24-bit counter

Register 2: timer preset value

Registers 3 & 4: 24-bit comparator

Registers 5–7: input, interrupt, external latch, counter, timer and comparator control bits

These registers are defined and assigned names using the IODEF or RIODEF statements in the system configuration task and then written to or read from the application program tasks using the assigned names.

**Two Axis Servo Module**

- 1.25 msec. update for velocity and position loops
- Absolute positioning range of 32 bits ( $+2.147 \times 10^9 \pm 8,388,607$  encoder edges)
- Direct bus interface with the DCS 5000/AutoMax processor
- Contains four optically isolated encoder interfaces for two channel incremental quadrature encoders with marker pulse
- Can be used with D-C or A-C industrial drives or analog servo amplifiers operating in either current or velocity loop mode
- Interfaces with standard incremental encoders (rotary or linear)
- Can be used with differential or single-ended encoders operating at 5 VDC
- Optically-isolated  $\pm 10V$  analog drive reference signal
- Optically-isolated open-collector drive enable output for each axis (5–24 VDC @ 5 mA) with LED status indicators
- Four optically-isolated limit switch inputs for each axis (24 VAC or D-C @ 5 mA) with LED status indicators:
  - Positive overtravel
  - Negative overtravel
  - Home
  - Drive fault
- On-board CPU watchdog with relay interlocked in the drive enable circuitry
- User interface cable and terminal board for all field connections

The Two-Axis Servo Module uses a single 80186 High Integration microprocessor to perform digital motion control for two axes.

Motion control hardware is supported in a custom motion control IC that contains interface to four encoders. The microprocessor interfaces to the DCS 5000/AutoMax processor module through a dual-port RAM device and other logic circuitry.

Four optically-isolated inputs on each axis provide direct interface to a home limit switch, positive and negative overtravel switches, and a drive fault switch. These inputs can be used with either mechanical switches, relays, or proximity detector operating on 24 Volts. Each axis also incorporates an optically-isolated drive enable output and two registration inputs. The micro-processor incorporates a CPU “watchdog” circuit with relay output for disabling external control devices in the event of a processor failure or other malfunction.

A self-tuning algorithm is used to exercise the system to optimize dynamic tuning of both the position and velocity loops and determine maximum acceleration and deceleration rates based on the system inertia and available torque.

**Software Features**

- Command registers control incremental and absolute trapezoidal indices, complex motion profiles, electronic gearing, tracking, jogging, and parameter initialization
- Automatic tuning of all servo loop gains
- Completely digital feedback control system with nested PIVF (proportional, integral, velocity, and feedforward) servo loop
- Electronic unwind allows unlimited travel for rotary axis
- Software selectable velocity loop allows module to drive a constant regulated speed without positioning to a specific point
- Electronic gearing allows gearing one axis to the other at a programmable 32-bit ratio; range of gear ratios is between  $5.960 \times 10^{-8}:1$  and 255.999:1
- Electronic cam allows up to 3830 points for each axis to define an arbitrary point-to-point position profile
- Dynamic range of velocity: up to 1,000,000 encoder counts/second
- Dynamic range of acceleration: up to  $3.28 \times 10^{10}$  encoder counts per second<sup>2</sup> (32-bit precision)
- Direct tracking allows complex motion profiles to be computed and downloaded by the DCS 5000/AutoMax in real time
- Easy access from DCS 5000/AutoMax software through symbolic programming and register commands
- Programmable velocity, acceleration, and deceleration
- Provides programmable 2X or 4X encoder line multiplication as well as step/direction and count up/count down encoder modes



## Multibus I/O System

Model No. 57C422

---

### Specifications

#### Encoder Specifications

Signal type: Differential TTL  
Signal level: 5 Volts  
Maximum input current: 4.5 mA  
Maximum frequency: 250 KHz/channel

#### Registration Input Specifications

Signal type: Electronic  
Operating voltage: 15–24v DC  
Maximum ON current: 6 mA  
Transport delay: 50 usec. max.

#### Sample Time

1.25 msec. on velocity and position loop

#### Limit Switch Input Specifications

Signal type: Contact or electronic  
Maximum Operating Voltage: 24 Volts AC or DC  
Maximum ON current: 6 mA  
Input filter: 30 Hz

#### Watchdog Output Specifications

Signal type: Contact  
Signal level: 5–24 Volts AC or DC  
Current rating: 1000 mA max

#### Drive Reference Specifications

Signal range:  $\pm 10$  Volts into a 10K Ohm load (12-bit resolution)

#### External Encoder Power Supply

Voltage: +5v DC  
Current: 250 mA + encoder requirements  
Regulation: .1%

#### Drive Reference Power Supply Specifications

Voltage: –12 to +15v DC  
Current: 25 mA  
Regulation: .1%



**RTD Input Module**

- Converts to degrees Fahrenheit or Celsius
- 2-3-4 wire RTDs
- 16 Channels of 100 Ohm platinum RTD input
- Broken wire detection
- Automatic calibration
- Running average 1–60 samples
- 4 alarm setpoints per channel
- 12 bit resolution plus sign

The RTD input module provides 16 channels of analog input for 100 ohm platinum resistance temperature detectors (RTDs).

Designed to provide the highest resolution and accuracy with 4-wire RTDs, the module is also compatible with 2-wire and 3-wire RTDs.

User termination to the RTD module is through separate RTD termination panels, which are available for flat panel (M/N 61C545) or DIN rail (model 61C546) mounting. These termination panels may be mounted up to 5 feet from the RTD module and are connected by cables which are supplied with the termination panels. Each termination panel is for 8 channels of RTD input so two panels are required when 9–16 RTDs are being connected to the input module.

The RTD module may be used in either local or remote racks. No external power supply is required for the RTDs.

Each of the 16 input channels consists of a constant current source and a pair of high impedance measurement inputs. The current sources are powered by an on-board supply that is isolated from the system common.

The module also contains positive and zero references for automatic A/D converter calibration. These references are checked at the end of each scan of the configured channels and the calibration coefficients are updated accordingly. No potentiometer adjustments are required to maintain the specified accuracy.

**Specifications****Channels**

- Number of Channels (RTDs): 16
- Commons: One analog common shared by 16 RTD channels
- Isolation: 2500V from analog common to digital ground

**RTD Elements**

- RTD Sensor Type:
  - 100 ohm platinum
  - alpha = 0.00385
  - ohm/ohm/°C
  - or 0.00392 ohm/ohm/°C
  - 4-wire, 3-wire, or 2-wire terminations
- RTD Excitation Current: 1 mA
- RTD Excitation Current Loading: 0 to 500 ohms
- RTD Temperature Range:
  - 200 to 500°C
  - 328 to 932°F

**Input Circuit**

- Resolution: 0.1°C
- Accuracy: 0.2% across the operating temperature range
- Input Impedance: 1000 Meg Ohms typical at 0 Hz

**Noise Rejection**

- Line Frequency Filter (Software Selectable): 60 Hz (default) to 60 samples per average
- Common Mode Rejection: –60 dB min (worst case value with averaging filter = 1)
- Normal Mode Rejection: –40 dB min (worst case value with averaging filter = 1)

**Timing**

Update Time per Channel:  
18.5 msec at 60 Hz  
22.0 msec at 50 Hz

- Channel Scan Time (16 Channels Configured):
  - 335 msec at 60 Hz
  - 400 msec at 50 Hz
- Integration Period (60Hz): 16.67 msec per temperature conversion per channel (50Hz): 20.00 msec per temperature conversion per channel

**Multibus I/O System**

Model No. 61C545, 61C546

**M/N 61C545 Panel Mount Terminal Board and Cable Assembly for 61C544**

The panel mount terminal board assembly provides terminals on a flat panel mounting surface for connecting the field wires coming from the RTDs. Also included is a cable to connect the terminals with the RTD module. The cable is five feet long. One assembly for each set of eight channels is required (2 per module).

M/N 61C545 Terminal Board and Cable Assembly  
(M/N 61C546 is similar)

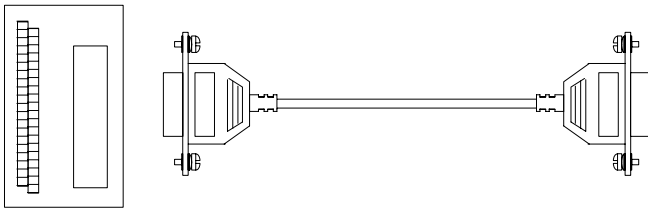

**M/N 61C546 DIN Rail Mount Terminal Board and Cable Assembly for 61C544**

The DIN rail terminal board assembly provides terminals on a DIN rail mounting surface for connecting the field wires coming from the RTDs. Also included is a cable to connect the terminals with the RTD module. The cable is five feet long. One assembly for each set of eight channels is required (2 per module).

M/N 61C546 DIN Rail-Mount Terminal Board

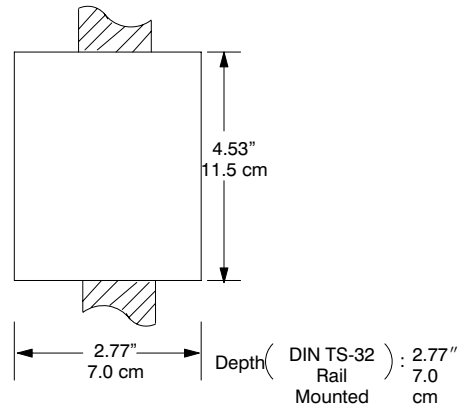

M/N 61C545 Panel-Mount Terminal Board

Hole Size: 0.27" x 0.20" Oval  
0.68 cm x 0.50 cm

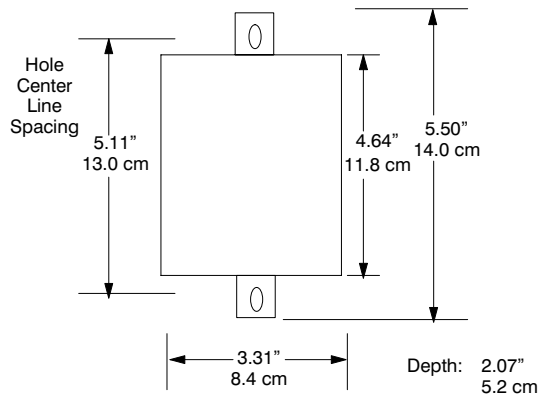

**Multibus I/O System****Model No. 61C605**

---

Due to suppliers discontinuing the manufacturing of custom chips, the 61C613 Analog/Thermocouple Input module, the 61C614 Thermocouple/Analog Termination Panel and the 61C605 Thermocouple Input module will no longer be manufactured.

It is unfortunate that these custom components are no longer available, but there are options that will allow the AutoMax to continue to deliver the exceptional performance it has come to stand for.

**Option 1:**

Rockwell Automation will continue to support repairs as long as components are available. If you require repair for one of these products, contact Rockwell Automation Repair at 1-800-669-6119 or 740-548-5733.

**Option 2:**

Replace the card with an Allen-Bradley I/O card from the 1771, 1746 or 1794 Flex I/O families that provides similar functionality. Some engineering will be required to add the replacement I/O to a new or existing network, rewire the data points, modify the AutoMax application software and to adjust for offsets.

**Option 3:**

If you only have a small number of points that require being monitored, you may choose to replace the obsolete module using a standard analog input card and analog signal converters. Some engineering will be required to specify the converter and reconfigure the rack for the analog card. An adjustment for range and offset will be required.

For assistance in implementing options 2 or 3, please contact your Rockwell Automation Local Drive Solution Center (see pages 7-7).

## Rail I/O System

Model No. 57C328, 61C22

---

### Rail-Mounted Digital I/O Modules

The Rail-Mounted Input/Output system is used for Remote I/O to provide rugged, full featured digital I/O that can be closely tailored to the application requirements.

The Rail Input/Output system consists of the following components:

- Input/Output Rail
- Remote Head
- Local Head
- Input/Output Modules

### Remote Head 57C328



The Remote Head is a communications adapter that interfaces to the AutoMax Remote I/O Network and provides four rail ports for I/O devices. A rail port will communicate with a Local Head, a Digital Input/Output Rail, an Analog I/O Rail or to the LED Output or the Thumbwheel Input Module. The Remote Head also is used to set the Remote Drop Node Address. It also includes a power supply which is capable of supplying power to four full rails of digital I/O modules. The Remote Head has:

- Remote Network Communications Port
- Remote Network Drop Address Switch
- Four I/O Communications Ports
- Fuse
- Terminal Strip
- Status Indicator



### Local Head 61C22



The Local head is a communications multiplexer that allows four digital I/O Rails to communicate to a single I/O communication port. This expands the number of digital I/O that can be connected to a Remote I/O Head from 64 to 256. The Local Head also includes a power supply capable of supplying power to four full rails of digital I/O modules. The Local Head has:

- One Remote Head Communication Port
- Four I/O Communication Ports
- Fuse
- Terminal Strip
- LED Status Indicator



**Rail I/O System****Model No. 45C1****Digital Input/Output Rail – 45C1**

The Input/Output Rail accommodates the mounting of the digital I/O rail modules and the interface to either the Local Head or directly to the Remote Head. The I/O Rail incorporates an industrial quality terminal strip which eliminates, in most applications, the need for wiring to an intermediate terminal strip. The Rail also provides heat dissipation and wiring management for the I/O Modules. A maximum of eight I/O Modules can be plugged into each Rail. Four I/O Rails can be connected directly to a Remote Head or to a Local Head.

**Certifications****Digital I/O Modules**

The Input/Output Modules provide the actual interface to the field equipment. A large selection of I/O Modules including various ratings of Digital I/O and a Voltage Comparator Module are available.

Each digital I/O Rail Module contains two channels, either input or output. All are electrically isolated, and include two diagnostic indicators per channel. The input modules have power and logic indicators, and the output modules have blown fuse and logic indicators. Each output channel is fused with a standard fuse that is easily accessible from the front of each output module.

All field wiring is terminated on the I/O Rail, and not the module. The modules may be quickly installed or removed without disturbing the field wiring.

Inputs:	Outputs:
M/N 45C40 115V ac/dc	M/N 45C60 115V ac
M/N 45C43 230V ac/dc	M/N 45C62 230V ac
M/N 45C44 24V ac/dc	M/N 45C63 24V dc
M/N 45C46 Voltage Comparator	M/N 45C65 115V dc
M/N 45C42 Electronic Input	M/N 45C66 Contact N.O.
	M/N 45C67 24V ac
	M/N 45C68 250V dc
	M/N 45C69 Dry Contact
	M/N 45C166 Contact N.C.

**Certifications****Analog Rail I/O Modules**

The Analog Rail Modules accommodate the interfacing of up to four analog signals to any rail I/O port. This includes the direct port, local Head port or the remote head. The analog module is a stand-alone panel mount device with either 4 inputs, 4 outputs or a combination of 2 inputs and 2 outputs. It incorporates an industrial quality terminal strip which eliminates the need to disturb field wiring.

The Analog Rail Modules incorporate a unique addressing feature, allowing either all four analogs to be updated to the processor in four registers, or multiplex four analog channels in one register. The latter allows the ability of quadrupling the physical I/O count.

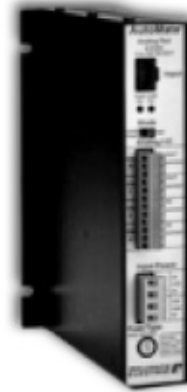
**Inputs/Outputs:**

M/N 61C345	4-20 mA Analog Input – 4 Channel
M/N 61C346	0-10V dc Analog Input – 4 Channel
M/N 61C365	4-20 mA Analog Output – 4 Channel
M/N 61C366	0-10V dc Analog Output – 4 Channel
M/N 61C350	0-10V dc Analog – 2 Input/2 Output Channels
M/N 61C351	4-20 mA Analog – 2 Input/2 Output Channels

**Certifications**

## Rail I/O System

Model No. 45C630, 45C631

---

Thumbwheel Switch Interface  
Module – 45C630

Led Interface Module – 45C631



The TWS and LED Interface Modules are configured as a rail in the AutoMate 15E, 20, 30, 40 or AutoMax processor locally or remotely or can be treated as numerical I/O when used with the AutoMate 30/40 or AutoMax processor. The data interface to these modules is binary coded decimal (BCD).

### Features

- Interfaces with AutoMate and AutoMax Controllers
- Easy to read characters
- Easy to mount and wire
- Designed for industrial environments

**Selection Charts****Model No. 57C402, 57C403, 57C420, 57C409, 57C410, 57C419, 61C500, 61C515, 61C540, 61C542A****Multibus Digital Input Cards**

Model Number	Type	Voltage Category	Operating Voltages	Number of Inputs	Max Input Delay	Cable M/N
61C516	ac/dc	24	19.2-30V RMS 19.2V RMS turn on 2.2V turn off	16	35 msec @ 50 Hz 26 msec @ 60 Hz 11 msec @ dc 4 inputs per iso. common	57C370 61C505 61C506
61C501	ac	115	132V rms 92V rms turnon 22V rms turnoff	16	35 msec @ 50 Hz 26 msec @ 60 Hz 4 inputs per iso. common	57C370 61C505 61C506
57C419	dc	5 to 24	2.7 to 24 V dc Sinking	32 total 4 latch	3.3 msec latch inputs 0.7 msec 4 inputs per iso. common	57C375

**Multibus Digital Output Cards**

Model Number	Type	Voltage Category	Operating Voltages	Number of Outputs	Max Continuous Current per Output	Cable M/N
57C402	ac/dc	24-115	132V RMS	16 4 outputs per iso. common	200 mA	57C370 61C505 61C506
57C403		115	132V RMS	16 4 outputs per iso. common	2 amp per output 4 amp per common 16 amp per module	57C370 61C505 61C506
57C420	dc	5 to 24	30V dc sourcing	32	750 mA per output 4 outputs per 1.8 a per common iso. common	57C376

**Multibus Analog Input Cards**

Model Number	Inputs	Type	Multibus Analog Input Cards		Update Speed	Cable M/N
			Isolation	Resolution		
57C409	2	0-10 V dc	Single common for both channels isolated from logic common by 600V	12 bits plus sign	.5 msec to 32.767 sec Adjustable filters Hardware interrupt	57C371
61C540	16	4-20 mA	One common 2500V from Analog Common To Digital Ground	12 bits plus sign	17 msec to 339 msec	61C549 Panel Mount 61C550 Din Rail
61C542A	8 single 16 diff.	+/- 10V	One common 2500V from Analog Common to Digital Ground	12 bits plus sign	10.6 msec to 343 msec	61C547 Panel Mount 61C548 Din Rail

**Multibus Analog Output Cards**

Model Number	Outputs	Type	Multibus Analog Output Cards		Update Speed	Cable M/N
			Isolation	Resolution		
57C410	4	+/- 10V	Individually isolated 2500V between common and outputs	12 bits including sign		57C370 61C505 61C506
		4-20 mA	With external power supply	11 bits sign always 0		

**Selection Charts**

**Model No. 57C411, 57C421, 57C422, 61C544, 61C605, 61C613**

**Multibus Specialty Cards**

Model Number	Inputs	Type	Multibus Analog Input Cards		Update Speed	Cable M/N
			Isolation	Resolution		
57C411 Resolver		2381 Hz		12 bits	500 usec to 32.767 sec Hardware interrupt External Strobe	57C373
57C421 Pulse/Tach	5 or 12 v		Single Dual Current sink or source	24 bit counter 24 bit comparator 16 bit internal counter Hardware interrupt External strobe	Freq. up to 150 kHz 500 usec to 32.767 sec.	57C372
57C422 Dual Axis Servo Module		1.25 msec speed		Gearing mode and position loop Position mode Cam mode Profile mode		57C377
61C544 RTD Input	16 channel	One common 2500V from analog common to digital ground		RTD Sensor Type 100 ohm Platinum	17 msec to 339 msec	61C545 8 channel Panel mount 61C546 8 channel Din Rail Mount
61C605 Thermocouple Input	<b>DISCONTINUED</b>					
61C613 Low Level Analog Input	<b>DISCONTINUED</b>					

**Resolver**

Model Number	Weight	Rotor Moment of Inertia	Shaft Diameter
57C360	21 lbs. 3 oz.	940 gm-cm <sup>2</sup>	0.625 inch
57C361	22 oz.	220 gm-cm <sup>2</sup>	0.375 inch



**Selection Charts**  
**Rail I/O****Rail Digital Input Modules**

Type	Voltage Category	Operating Voltages			Number of Inputs	On Signal Delay (typical)	Off Signal Delay (typical)	Max Off-State Current	Typical On-State Current	Module Model Number	Applications 1,2
		Voltage Max	On State	Off State							
ac/dc	115V ac	130V	80V	60V	2	2.0 ms after threshold exceeded	19.0 ms after threshold removed	3 mA	6.3 mA	45C40	General-purpose 120V ac/dc inputs
	115V dc		108V	83V							
	230V ac	255V	150V	120V	2	2.0 ms after threshold exceeded	19.0 ms after threshold removed	2 mA	4.4 mA	45C43	General-purpose 230V ac/dc inputs
	230V dc		203V	165V							
	24V ac	40V	16.5V	10.5V	2	2.0 ms after threshold exceeded	19.0 ms after threshold removed	1 mA	7.8 mA	45C44	General-purpose 24V ac/dc inputs
	24V dc		20V	14.5V							
Electronic Input	24V dc	24V	3.5V	1.0V	2		Requires pulse with a minimum width of 500 Microseconds		Varies from 19.4 mA @ 3.5V dc to 26.4 mA @ 24V dc	45C42	General-purpose low level dc inputs
Analog Signal Comparator	0-10V dc (adjustable)	10V dc	Adj.	0.02V	2					45C46	Meter-relay function. Compares (2) levels against each other or compares (1) level against a reference. Has an adjustable 0-3V dc deadband

1 Each module occupies one slot of the 45C1 Digital Rail

2 All digital input modules, except for the 45C46 Analog Comparator Input Module, have two isolated input channels. The channels do not share the signal common. Also, opto-isolators are used on each channel to provide up to 2500 V (RMS) isolation between the channels input circuit and its logic circuit.

**Remote Head**

Model No.	Description	Voltage Category	Voltage Range	Applications
57C328	AutoMax Remote I/O Head	120V ac	102-132V ac	Remote drop interface for both digital and analog rails
		240V ac	204-254V ac	

**Local Heads**

Model No.	Description	Voltage Category	Voltage Range	Applications
61C22	Local Head	120V ac	102-132V ac	Used with Digital Rails only
61C23	Local Head	24/48V dc	20-55V dc	Used with Digital Rails only
45C8	Local Head Interconnect Cable	10 Ft.	n/a	Used between Remote Head and Local Head

1 Does not include power conductors.

**Digital Rails**

Model No.	Description	Cable Length	Applications
45C1	Digital I/O Rail	n/a	Holds up to eight rail modules
45C2	Digital I/O Rail Motherboard	n/a	Included with the 45C1 Rail
45C3	Digital I/O Rail Jumper Bar Kit	n/a	Has parts to support 4 Rails
45C4	Digital I/O Rail Cable Channel	n/a	Has parts to support 4 Rails
45C5	Digital I/O Rail Interconnect Cable	42 Inches	Included with the 45C1 Rail

**Selection Charts**

**Rail Digital Output Modules**

Type	Voltage Category	Operating Voltage	Number of Outputs	Type Output Device	Max. Continuous Current per Output	Max. Surge Current per Output	Max Continuous Current per Module	Max	Maximum Holding Current	Module Model Number	Applications
								Off-State Current			
ac	120V	80 to 132V RMS	2	Triac	2A	20A (0.1 sec.) 10A (0.5 sec.)	4A	5.9 mA	70 mA	45C60	General purpose isolated outputs
	240V	200 to 270V RMS	2	Triac	2A	20A (0.1 sec.) 10A (0.5 sec.)	4A	8.1 mA	70 mA	45C62	General purpose isolated outputs
	24V	10 to 35V RMS	2	Triac	2A	20A (0.1 sec.) 10A (0.5 sec.)	4A	1.2 mA	70 mA	45C67	General purpose isolated outputs
dc	24V	15 to 40V	2	FET	2A	8A (0.1 sec.) 4A (0.5 sec.)	4A	1 mA		45C63	General purpose isolated outputs
	120V	83 to 140V	2	FET	2A	8A (0.1 sec.) 4A (0.5 sec.)	4A	1 mA		45C65	General purpose isolated outputs
	250V	15 to 40V	2	FET	0.5A	1.5A (0.1 sec.) 1A (0.5 sec.)	1A	4 mA		45C68	General purpose isolated outputs
normally open relay contacts	250V ac	1 to 250V RMS	2	N.O. Relay	3A		6A	4.6 mA at 125V RMS 9.2 mA at 250V RMS		45C66	Individually isolated high-current relay outputs
	30V dc 110V dc	1 to 30V dc	2	N.O. Relay	5A @ 30V dc 0.6A @ 110V dc		10A				
normally closed relay contacts	250V ac	1 to 250V RMS	2	N.C. Relay	3A		6A	4.6 mA at 125V RMS 9.2 mA at 250V RMS		45C166	
	30V dc 110V dc	1 to 30V dc	2	N.C. Relay	5A @ 30V dc 0.6A @ 110V dc		10A				
normally open dry relay contacts	125V ac	0.1 to 125V ac	2	N.O. Relay	0.4A @ 125V ac Resistive		50 VA 60 W			45C69	Used for switching low level analog signals or low level digital signals where leakage is not acceptable
	30V dc	0.1 to 30V dc	2	N.O. Relay	1.0A @ 30V dc		50 VA 60 W				

1 Module has leakage current due to dvdt circuitry which is incorporated into module design.

2 Module does not have leakage current as it does not have any dvdt circuitry incorporated into its design.

**Selection Charts****Rail Analog Modules**

Type	Signal Category	Number of Channels	Channel Resolution	Output System						Analog Module Power Supply		Module Model Number	Applications 1
				Input Impedance	Channel Update	Input Filter	Output Load	Output Current	Settling Time	120 V ac Line	24 V dc Line		
Input	4-20 mA dc	4 Inputs	12 bit binary	278 ohms (1)	13 usec	2nd Order 180 Hz LP	n/a	n/a	n/a	92-132 V ac at 150 mA	20-32 V dc at 350 mA	61C345	
	0-10V dc	4 Inputs	12 bit binary	180 K ohms	13 usec	2nd Order 160 Hz LP	n/a	n/a	n/a	92-132 V ac at 150 mA	20-32 V dc at 350 mA	61C346	
Output	4-20 mA dc	4 Outputs	12 bit binary	n/a	n/a	n/a	1450 ohms	n/a	200 usec	92-132 V ac at 150 mA	20-32 V dc at 350 mA	61C365	
	0-10V dc	4 Outputs	12 bit binary	n/a	n/a	n/a	500 ohms	20 ma at 10 V dc	100 usec	92-132 V ac at 150 mA	20-32 V dc at 350 mA	61C366	
Input/Output	4-20 mA dc	2 Output/ 2 Input	12 bit binary	278 ohms (1)	13 usec	2nd Order 160 Hz LP	1450 ohms	n/a	200 usec	92-132 V ac at 150 mA	20-32 V dc at 350 mA	61C351	
	0-10V dc	2 Output/ 2 Input	12 bit binary	180K ohms	13 usec	2nd Order 160 Hz LP	500 ohms	20 mA at 10 V dc	100 usec	92-132 V ac at 150 mA	20-32 V dc at 350 mA	61C350	

1 All channels share the same analog common.

**Specialty I/O Modules**

Model No.	Description	Data Encoding	Number of Digits	Cable Included	Applications
45C630	Thumbwheel Switch Module	BCD	Four	45C5	Four Digit Data Entry for Operators Station
61C23	LED Interface Module	BCD	Four	45C5	Four Digit Data Display for Operators Station

1 The 45C8 Local Head Cable can be used if the user provides an external source of 5 V dc to the Module.

**Multibus I/O Modules**

**Cable and Terminal Board Assembly Information**

Assembly Model No.	Terminal Assembly Part Number	Cable Assembly Part Number	Cable Length	Number of Terminal Boards	Number of Terminals per Terminal Board	Terminal Board or Assembly Dimensions H x W (Inches)
45C175*	707226-10C	-	-	1	8	-
45C176*	707226-10J	-	-	1	20	-
57C370	-	612401-60R	60"	1	20	9.50" x 1.375"
57C371	-	612417-60R	60"	1	10	5.13" x 1.375"
57C372	-	612422-76R	60"	1	20	9.50" x 1.375"
57C373	-	612426-60R	60"	1	10	5.13" x 1.375"
57C375	-	612438-R	60"	2	20	9.50" x 1.375"
57C376	-	612439-R	60"	2	12	6.00" x 1.375"
57C377	610296-1A	612437-60R	60"	2	20	9.50" x 1.375"
61C505	612563	612561-60R	60"	1	20	2" x 6.75"
61C506	612563-1	612562-60R	60"	1	20	2" x 6.75"
61C545	610296-1B	613204-60R	60"	1	-	**4.64" x 2.77"
61C546	610296-3A	613204-60R	60"	1	-	4.53" x 2.77"
61C547	610296-3B	613204-60R	60"	1	-	**6.70" x 3.43"
61C548	610296-2A	613204-60R	60"	1	-	6.70" x 3.43"
61C549	610296-2A	613204-60R	60"	1	-	**6.70" x 3.43"
61C550	610296-2B	613204-60R	60"	1	-	6.70" x 3.43"
61C614	DISCONTINUED					

\* Terminal block/connector which mounts on faceplate of multibus I/O module.

\*\* Indicates that the 61C545, 61C547 and 61C549 Terminal Assemblies have mounting flanges on their vertical centerline. Check terminal assembly pages for dimensions of flanges.

**Input/Output System**

**Dimensions**

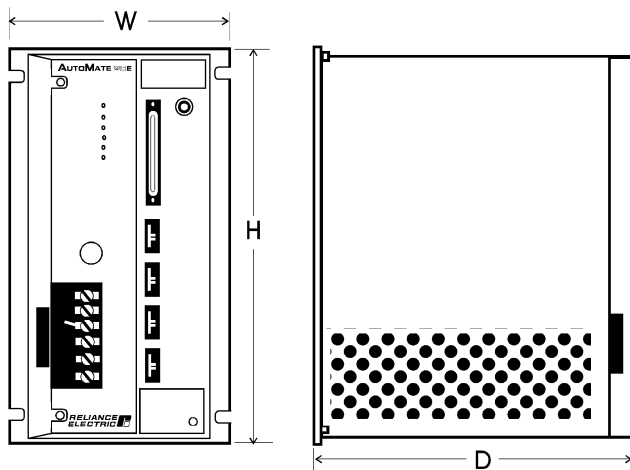

	W	H	D
Remote I/O Head	5 <sup>1</sup> / <sub>2</sub> "	9 <sup>1</sup> / <sub>2</sub> "	9 <sup>1</sup> / <sub>2</sub> "
Local Head	5 <sup>1</sup> / <sub>2</sub> "	3 <sup>1</sup> / <sub>2</sub> "	9"
Digital I/O Rail	5 <sup>1</sup> / <sub>2</sub> "	9"	7 <sup>5</sup> / <sub>8</sub> "
Analog I/O Rail	3"	9 <sup>1</sup> / <sub>4</sub> "	7 <sup>3</sup> / <sub>4</sub> "
TWS Module <sup>1</sup>	4 <sup>1</sup> / <sub>2</sub> "	2 <sup>1</sup> / <sub>4</sub> "	7 <sup>1</sup> / <sub>2</sub> " <sup>1</sup>
LED Module <sup>1</sup>	4 <sup>1</sup> / <sub>2</sub> "	2 <sup>1</sup> / <sub>4</sub> "	7 <sup>1</sup> / <sub>2</sub> " <sup>1</sup>

<sup>1</sup> Panel cutout is 45 x 92 mm

<sup>2</sup> Front bezel projects <sup>7</sup>/<sub>16</sub>" from panel. Overall depth is 7<sup>15</sup>/<sub>16</sub>" (including signal cable).

**Digital Inputs**

**61C516**  
Typical Field Signal Connections

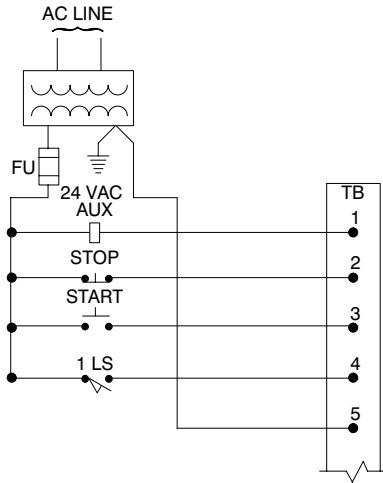

**61C501**  
Typical Field Signal Connections

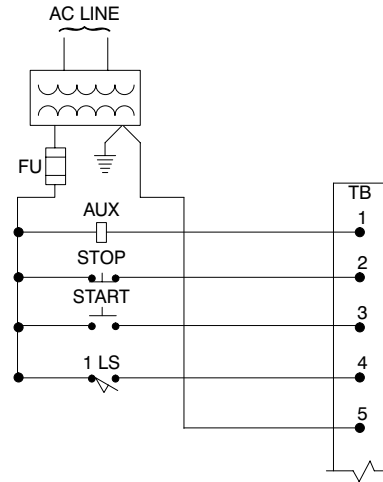

**57C419**  
Typical Field Connection for Contact Closures

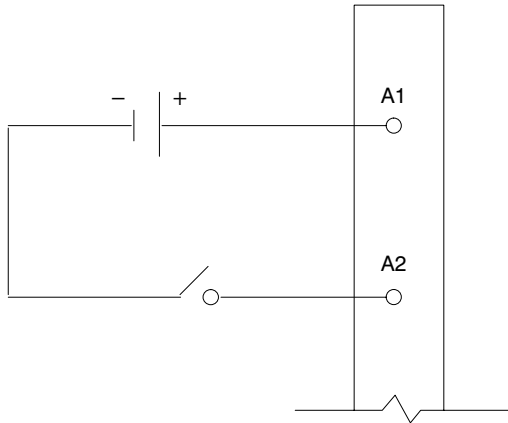

**57C419**  
Typical Field Connections for Open Collector TTL

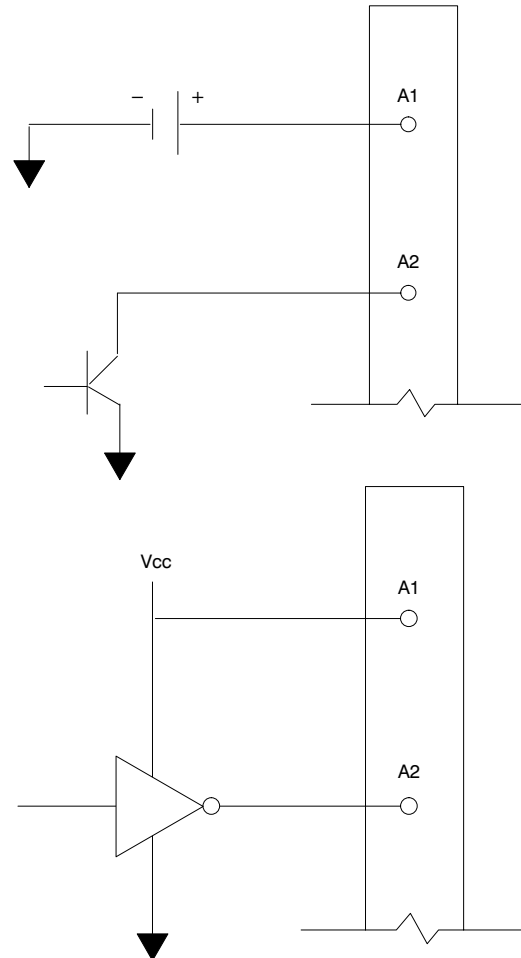

## Connection Diagrams

Model No. 57C402, 57C403, 57C420

### Digital Outputs

#### 57C402 Typical Field Signal Connections

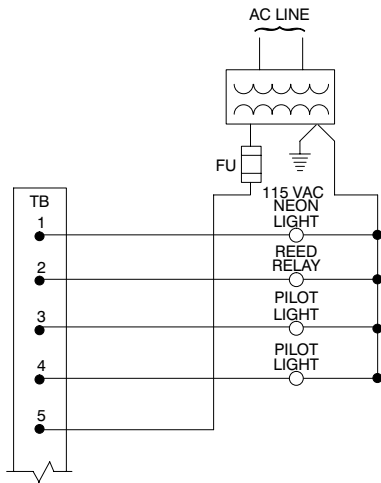

#### 57C403 Typical Field Signal Connections

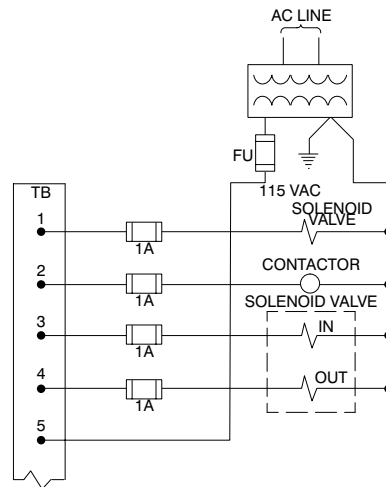

#### 57C420 Typical External Current Limit Resistor

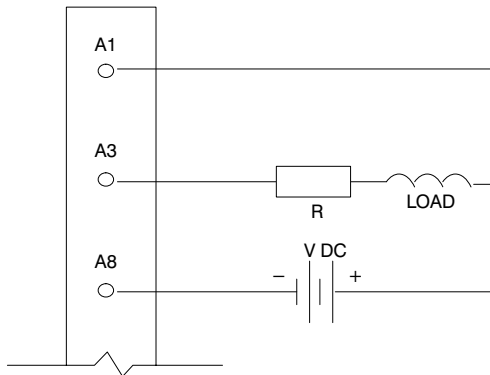

$$R = \frac{\text{Supply Voltage}}{.75}$$

**Connection Diagrams**

Model No. 57C409, 61C540A, 61C542A

**Analog Input**

**57C409  
Typical Field Signal Connections**

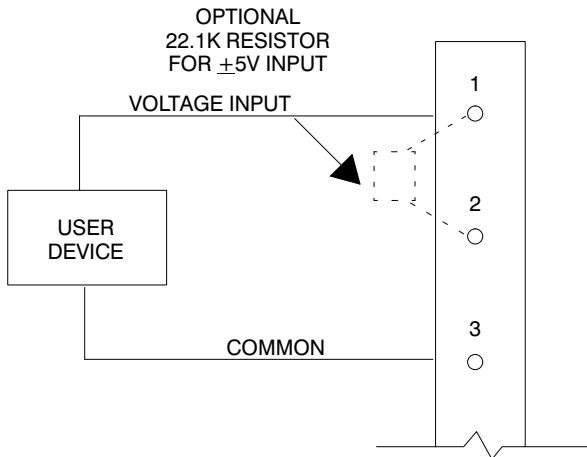

**61C540A  
Transmitter Wiring Connections**

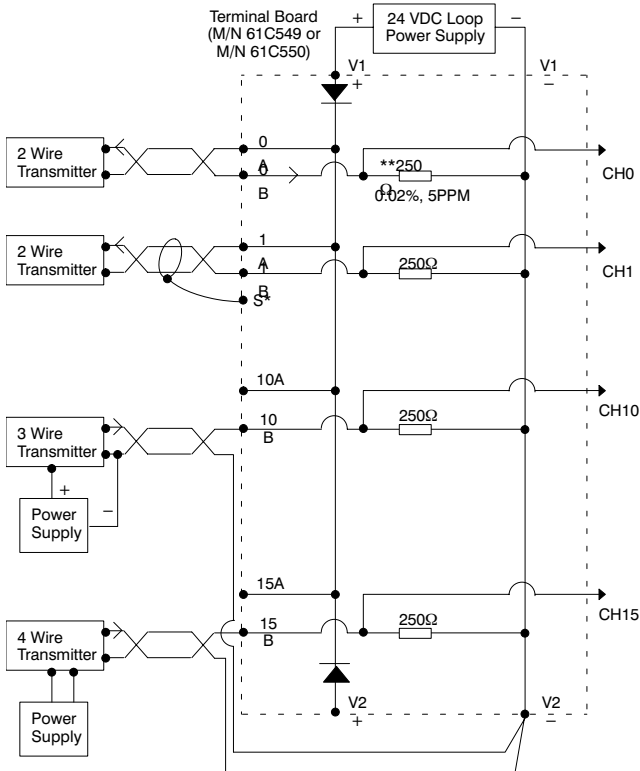

\* Typical shield connection is shown on channel 1.  
\*\* 250Ω resistors are factory-installed in the M/N 61C549 and 61C550 terminal boards.

**61C542A  
Transmitter Wiring Connections**

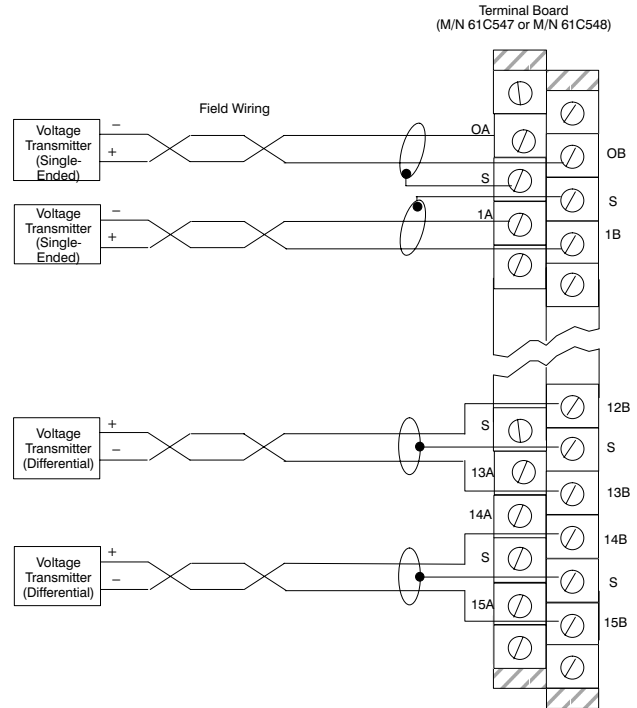

- Notes:**
- (1) All "A" terminals (0A-15A are tied to the analog common bus.
  - (2) All analog inputs must be within ±10V of analog common for proper operation.

## Connection Diagrams

Model No. 57C410, 57C421

### Analog Output

**57C410**  
Typical Field Connections for Voltage Output

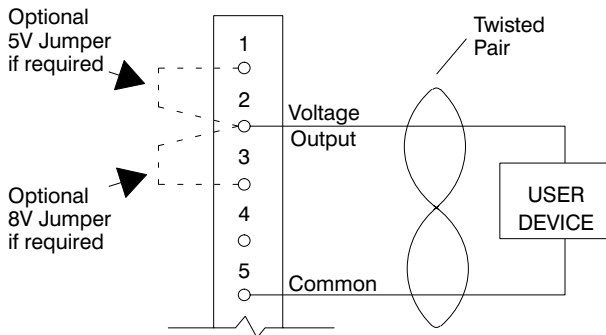

**57C410**  
Typical Field Connections for 4-20 mA Current Output

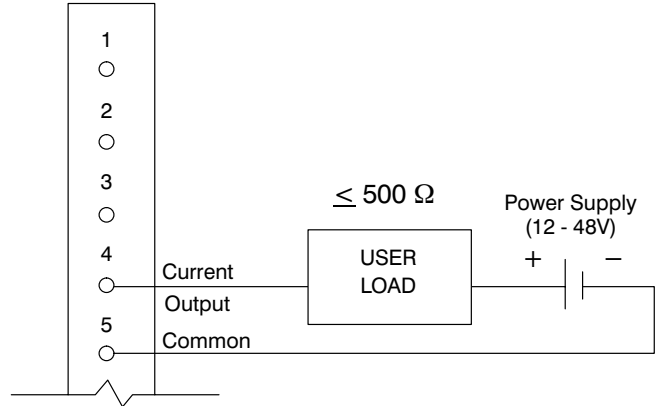

### Specialty I/O

**57C421**  
Typical Pulsetach Connections for a 5V dc Differential Input

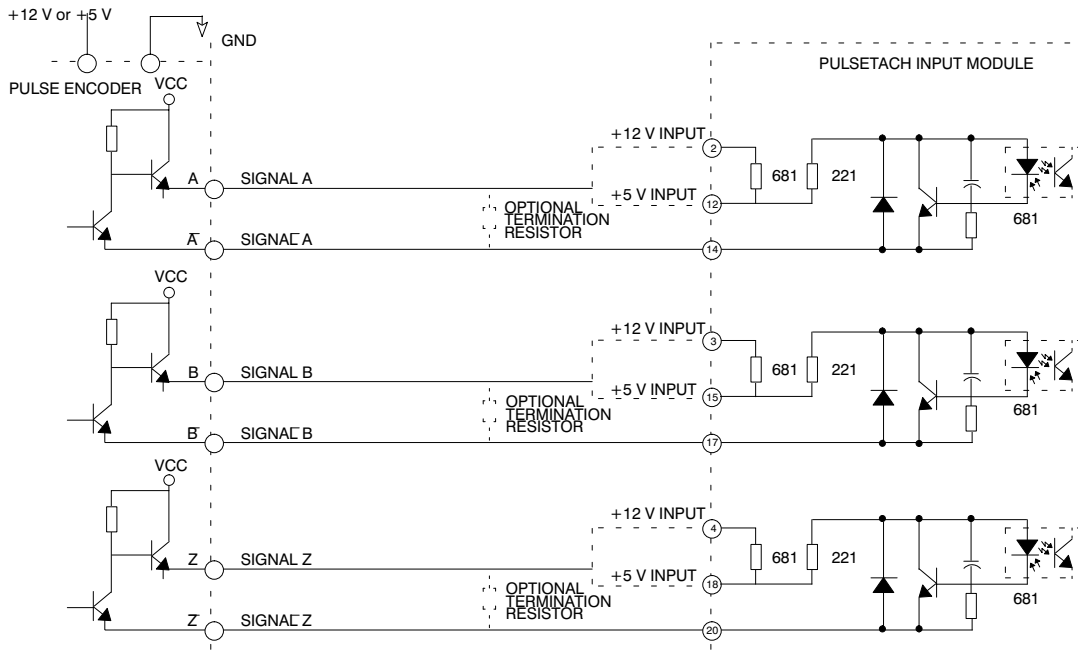



**Specialty I/O**

**57C411  
Typical M/N 57C360 Resolver Field Connections**

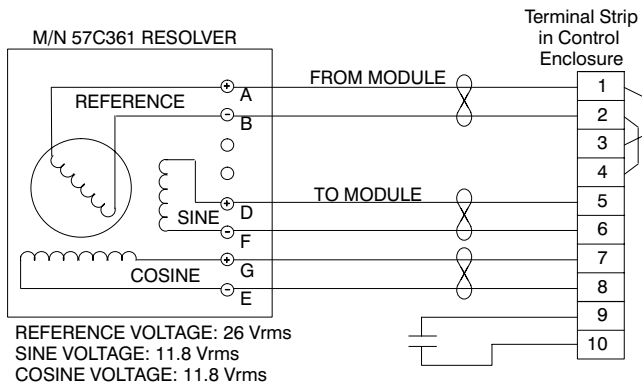

**57C411  
Typical M/N 57C361 Resolver Field Connections**

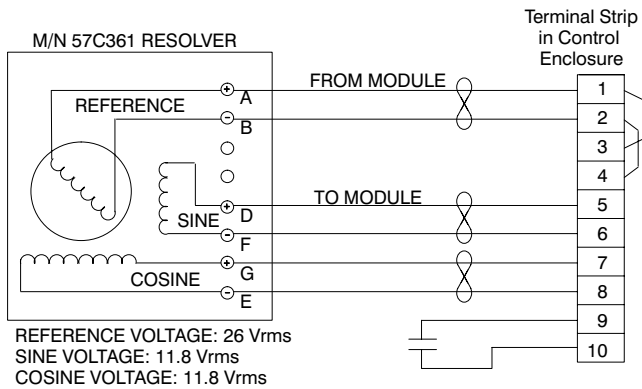

**61C544A  
RTD Wiring Connections**

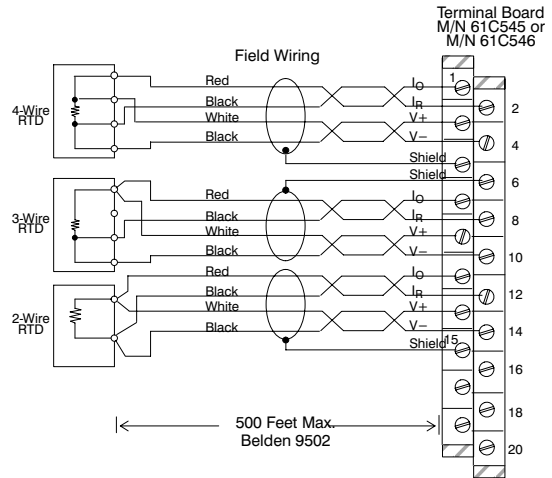

**61C544A  
RTD Module Connections**

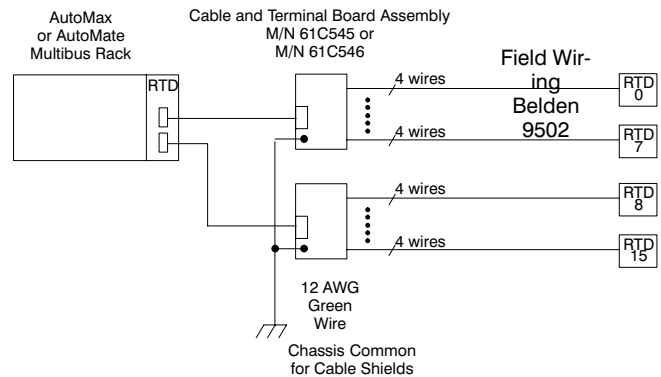

## Connection Diagrams

Model No. 61C605, 61C613

### Specialty I/O

#### 61C605

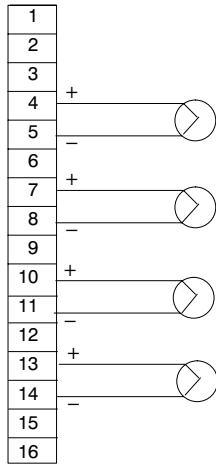

#### 61C613

### Typical Field Signal Connections w/Thermocouple Panel

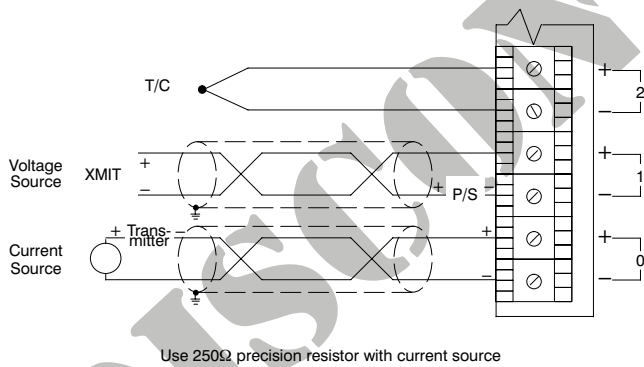

**Connection Diagrams**

Model No. 45C40, 45C42, 45C43, 45C44, 45C46, 45C60, 45C62, 45C63, 45C65, 45C66, 45C67, 45C68

**45C40, 45C43, 45C44  
Dual AC/DC Input Module Field Wiring Example**

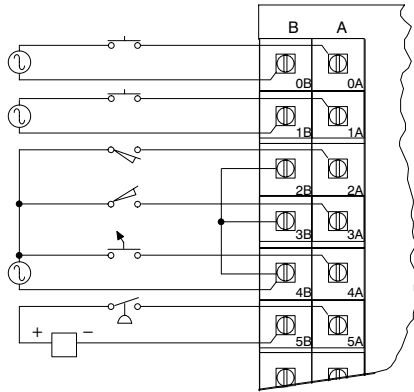

The circuits shown are for illustration only.

**45C60, 45C62, 45C67  
Dual AC Output Module Field Wiring Example**

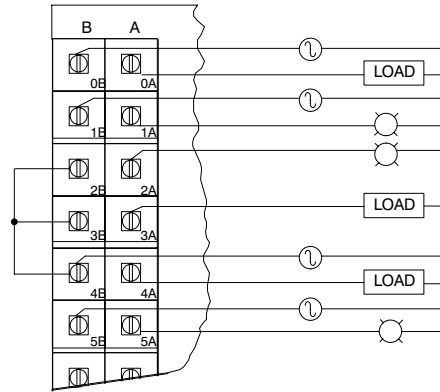

The circuits shown are for illustration only.

**45C42  
Dual Electronic Input Module Field Wiring Example**

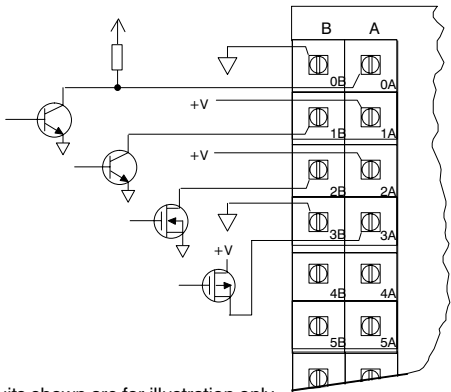

The circuits shown are for illustration only.

**45C63, 45C65, 45C68  
Dual DC Output Module Field Wiring Example**

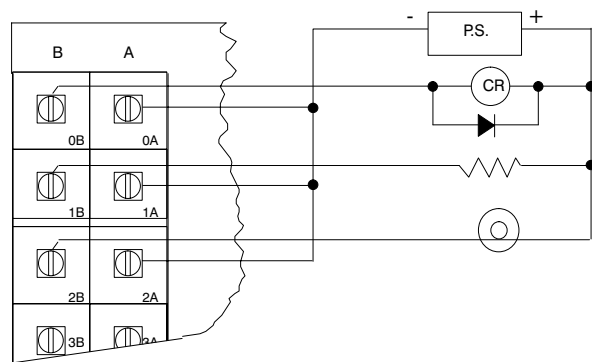

The circuits shown are for illustration only.

**45C46  
Voltage Comparator Module Field Wiring Example**

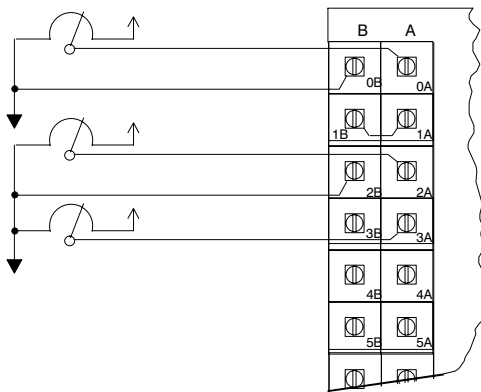

The circuits shown are for illustration only.

**45C66  
Dual Contact Output Module (N.O.)  
Field Wiring Example**

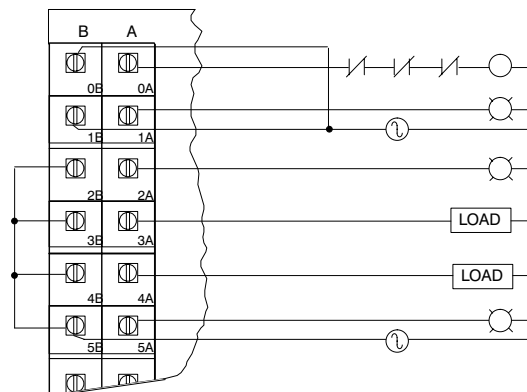

The circuits shown are for illustration only.

## Connection Diagrams

Model No. 45C69, 45C166, 61C345, 61C346

### 45C166 Dual Contact Output Module (N.C.) Field Wiring Example

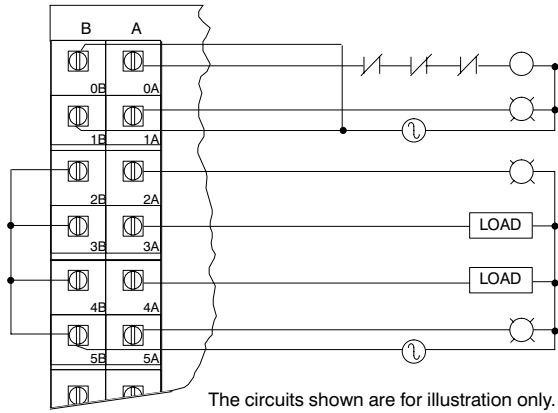

### 45C69 Dual Contact (N.O.) Low Power Field Wiring Example

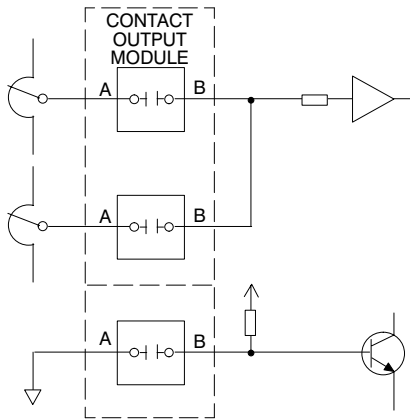

### 61C345 Analog Rail, 4 Channel, 4-20 mA D-C Field Wiring Example

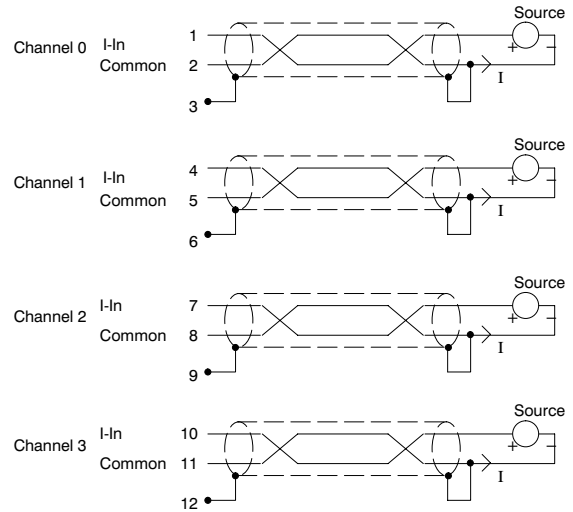

### 61C346 Analog Rail, 4 Channel, 0-10v DC Field Wiring Example

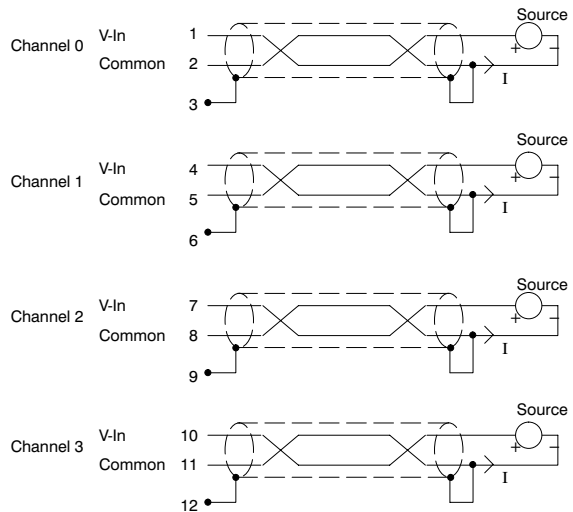

**Connection Diagrams**

Model No. 61C350, 61C351, 61C365, 61C366

**61C350**  
Analog Rail, 2 In/2 Out, 0-10v DC  
Field Wiring Example

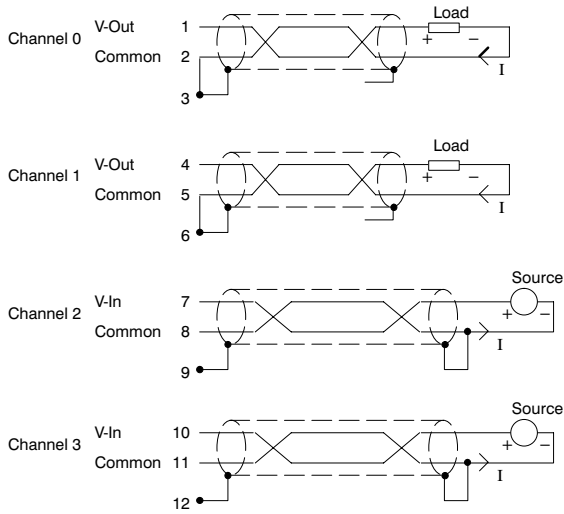

**61C365**  
Analog Rail, 4 Output, 4-20 mA DC  
Field Wiring Example

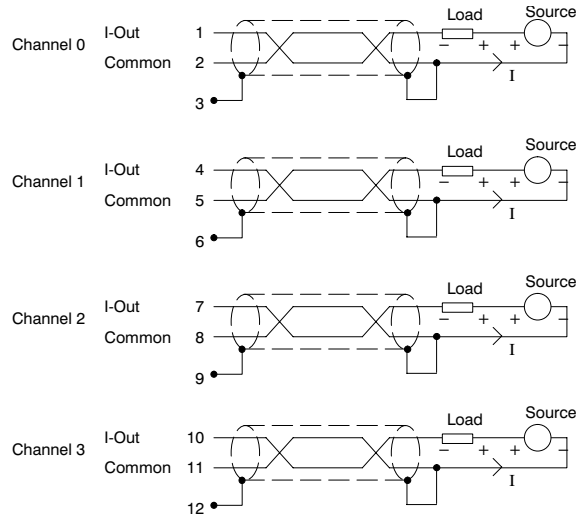

**61C351**  
Analog Rail, 2 In/2 Out, 4-20 ma DC  
Field Wiring Example

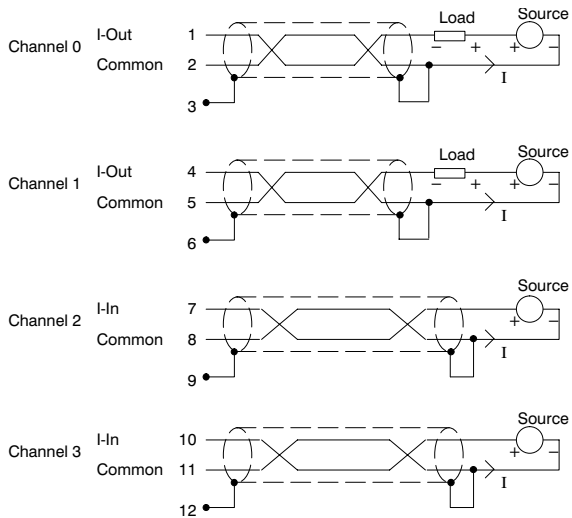

**61C366**  
Analog Rail, 4 Output, 0-10v DC  
Field Wiring Example

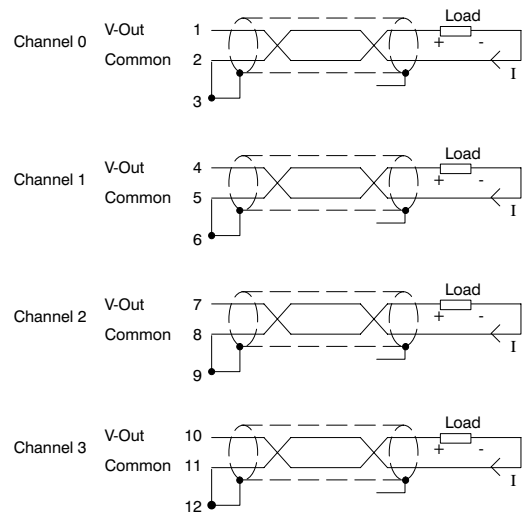

## Allen-Bradley Remote I/O

---

### Introduction

Allen-Bradley offers a wide range of devices that connect to their remote I/O network. These devices include I/O modules, operator interface devices and variable speeddrives along with many special purpose modules. This section of the catalog deals with some of the different Allen-Bradley I/O devices and product families that can connect with AutoMax.

The product families touched on are:

- 1746 SLC I/O
- 1771 PLC I/O
- 1791 Block I/O
- 1794 Flex I/O

The ability to connect to the Allen-Bradley network and take advantage of the wide range of available devices gives the AutoMax user great flexibility in his installation. **For more information and specifications, we recommend that the local Allen-Bradley sales office or distributor be contacted or go to [www.ab.com](http://www.ab.com).**

### AutoMax Connectivity to Allen-Bradley I/O

The built-in remote I/O network for the AutoMax PC3000 only supports Allen-Bradley remote I/O. This network will support up to 32 racks of I/O.

The Multibus based AutoMax uses the 57C443 A-B Remote I/O Scanner module to provide connectivity to Allen-Bradley compatible devices. Multiple 57C443 Scanner modules may be utilized by one processor rack system. Each scanner module will support up to 32 racks of Allen-Bradley I/O.



DISTRIBUTED CONTROL SYSTEM

## Programming Support Tools

---

<b>Programming Executives Selection Chart</b> .....	4-2
---	-----

### **Executives**

AutoMax Version 4 .....	4-3
AutoMax Version 3 .....	4-5
AutoMax Version 2 .....	4-7

### **Selection Charts**

Programming Executives .....	4-9
Distributed Power System (DPS) Software .....	4-10
Documentation Sets .....	4-10

## Programming Executives Selection Chart

---

	V2	V3	V4
6011CPU	X	X	X
7010CPU	X	X	X
PC3000			X (V4.1 or later)
DOS	X		
Windows 3.1		X	
Windows 95/98		X (3.8+)	X
Windows NT		X (3.9)	X (4.3+)
Windows 2000		X (3.9)	X (4.3+)
Windows XP		X (3.9)	X (4.3+)
DPS		X	X



**Programming Executives****Model No. 57C610****The AutoMax Programming Executive – Version 4**

The goal of the AutoMax-DCS products are to provide a single programmable platform for highly integrated drive control systems. The AutoMax-DCS continues to provide an unparalleled control environment for drives and motion applications with its high speed networks to the Reliance Distributed Power Drives and standard AC and DC drives from Rockwell Automation. With the introduction of the Version 4 Programming Executives, AutoMax now significantly simplifies the programming and maintenance of the ladder language portion of complex drive control processes. These new ladder language enhancements are in addition to all of the existing control and language features that are built into the current AutoMax system.

Some of the new features that are incorporated in the AutoMax V4 software are:

**Expanded Ladder Language**

- Allows multiple instruction blocks and output coils per rung.
- Expanded rung size (up to 40 elements across and 24 elements down)
- Easy bit addressing of numeric/integer variables (SPEED.15)
- Variable names expanded to 16 characters

**Graphic Ladder Editor**

- A rich set of graphic tools
- Simultaneous viewing of multiple windows within a program and between different programs
- Extensive context-sensitive help screens
- Windows 95/98 editing features (Cut/Copy/Paste, Drag & Drop) for elements, groups of elements, complete rungs, and groups of rungs
- User configurable editor desktop (selectable screen colors, palette locations, printout options, etc.)
- “Smart-Matching” minimizes typing by remembering and matching variable names as new instructions are added.

**Versatile Online Tools**

- Same editor for both online and offline services
- All program documentation can be viewed online
- Ability to simultaneously edit multiple rungs in a single edit
- Identifies (color codes) inserted, deleted and modified rungs
- Test mode for verifying changes before committing them to permanence
- Capture trigger provides a transitional “snap shot” of a rung for troubleshooting

The primary changes introduced with V4 are in the ladder language and ladder editor. All other programming tools such as the graphic configurator are the same as in AutoMax V3 executives. PLUS, Version 4 is completely backward compatible with any previous version AutoMax executive. Configurations and programs can be directly imported and converted to V4 with minimal programming efforts. The charts on the following pages are provided to help you understand and select the best model of the AutoMax Version 4 for your application needs.

**Notes**

1. Programming for the Universal Drive Controller Module (UDC) used in DPS systems using the AutoMax V4 Executive must use the appropriate DPS software options.
2. V4 will operate with the 6011, 7010 and PC3000 processors. Microsoft Windows 95/98/NT/2000 is required with all version 4 software packages.
3. Multicopy discount program requires purchase of three full AutoMax Executive software packages at the same customer location. Manuals are extra. Consult factory for program details.
4. The 57C650 LDS\* license allows 5 users to access each of the DPS software options which are installed on the file server. To program a DPS system in a shared user environment requires a shared user development package (57C625\*\*) plus 57C650 LDS\* plus the appropriate DPS options.
5. DPS software options are used to program the UDC Module in Distributed Power Systems. They are used in conjunction with the AutoMax full or runtime versions of software executive. Licensing for DPS software options is the same as for the executive software – one copy per personal computer. Each DPS software option includes the manual for that particular software.
6. The Executive upgrade packages update earlier AutoMax Executive versions to the latest software of the version selected.
7. DPS software options are provided with software and installation manual only.

\*Local Drive Solutions

\*\*Discontinued

**Contact the Local Drive Solutions Center  
at 440.646.7202.**

## Programming Executives

Model No. 57C610

---

### Personal Computer Requirements Version 4

#### Minimum Hardware

IBM PC-compatible personal computer  
Pentium or higher processor  
16 MB RAM (recommended)  
18 MB of hard disk space (41 MB for installation)

Significant improvements in performance will occur by adding additional memory capability.

#### Software

Microsoft Windows 95/98/NT/2000/XP.

The Version Control Library feature (if used) requires the Intersolv™ Polytron Version Control System, Version 5.0 or later to be purchased separately.

#### Note on License Agreement

Single-user versions of ReSource Programming Executive software are licensed for use on a single central processing unit (personal computer). Shared-user versions may be installed on a file server for simultaneous access by a limited number of users. For full copy of the license agreement request ZJ-117-1.

**Programming Executives**

Model No. 57C610

**The AutoMax Programming Executive – Version 3**

This version of the AutoMax Programming Executive is a Microsoft Windows-based software package that enables the programming and documentation of the AutoMax DCS application software, and includes the operating system for all AutoMax processors.

Version 3 allows the user to quickly and easily configure an AutoMax DCS application through the use of mouse-driven pull-down menus which provide visual displays and selection of AutoMax control system components. Beginning with an empty rack, the user selects the appropriate modules from pull-down menus, and, using a mouse, places them in their correct slots within the rack. Each module is then given its corresponding addressing information.

Using a mouse, and simple pull-down menus allows the quick and easy configuration of AutoMax control systems ranging from basic single rack systems to multiple rack control networks.

AutoMax Version 3 software will run any V3.x or V2.x task without recompiling or converting these previously written tasks. Version 3 is also compatible with the 6011, and 7010 AutoMax processors, as well as the Universal Drive Controller (UDC) processor.

In addition to its ease of use, other major enhancements are provided by AutoMax Version 3 software. These include:

- Support for AutoMax Distributed Power Software
- Direct network connection via AutoMax PC Link module
- Accommodates up to four on-line users per rack
- Variable processor tick rates
- Shared-user version available for file server installation
- Support for file tokens and locking
- Support for software version control library
- Enhanced printing capabilities
- Version 3.9 or later supports Windows 95/98/NT/2000/XP

**Support for AutoMax Distributed Power**

Distributed Power is a major AutoMax enhancement which allows the drive power module to be separated from the control rack by up to 750 meters through the use of fiber optics. AutoMax Version 3 software or later is required for all Distributed Power applications.

The control block programs for drive control will execute in the Universal Drive Control (UDC) module rather than in the AutoMax processor. AutoMax Version 3 software allows complete configuration and programming of not only the UDC modules, but the modules contained in the Power Module Interface (PMI) rack, as well when the appropriate DPS software options have been added.

**Direct network connection via AutoMax PC Link module**

AutoMax Version 3 software allows a direct connection between the personal computer running the executive and the DCS network through the AutoMax PC Link module.

**Accommodates up to four on-line users per rack**

Up to four users may simultaneously enter passwords and perform online operations in each AutoMax rack. This facilitates the start-up and commissioning of Distributed Power applications, in which up to 20 drives may be controlled from a single rack.

**Variable processor tick rates**

AutoMax processor tick rates are now user-selectable in 0.5 millisecond increments, ranging from 0.5 to 10 milliseconds. This allows the user to fine tune the execution of critical tasks.

**Shared-user version available for file server installation**

A shared-user version is now available for installation on a file server. This allows up to 5 simultaneous users access to the software executive. Additional groups of 5 users may be added to the software license, and provides a cost-effective way for an engineering office to share copies of the AutoMax Version 3 software.

**Support for file tokens and locking**

Tokens provide a means of write-protecting the databases and tasks for one or more racks or an entire system when using AutoMax Programming Executive in a network environment, and are used to ensure that only one copy of a file can be modified. The AutoMax system will lock the appropriate files to ensure that the user has exclusive access to them. Locking prevents more than one user at a time from changing the same database information (when that information is stored on a file server), and notifies any other user attempting to modify the same file that this file is locked by another user.

**Support for software version control library**

The Version Control Library (VCL) provides an interface to the Polytron Version Control System (PVCS) by Intersolv. The PVCS system is not required in order to use AutoMax Version 3 Software, and is not distributed as part of the AutoMax Programming Executive. You must, however, have PVCS Version 5.0 (or later) installed on your network or local drive in order to use the VCL features in AutoMax Version 3.

As a control system is developed, the programmer may find it useful to snapshot all or part of the system, either as milestones are reached, or when files are handed off to another user. VCL is used to save versions of systems, sections, racks, or tasks.

Users can view the contents of the Version Control Library and retrieve previous versions (or the most current version) of the files contained in the VCL. Any files that have been previously stored in the library can be recalled.

## Programming Executives

Model No. 57C610

---

### Enhanced Printing Capabilities Version 3

Printing is now available at the systems, section, and rack levels. The system, section, and rack printouts also include standard page headers, configurable number of lines per page, and an optional top margin.

### Personal Computer Requirements Version 3

#### Hardware:

- IBM PC compatible computer
- 80386 or higher processor (Pentium for Windows 95/98)
- 2 MB RAM (16 MB for Windows 95/98)
- 7 MB hard disk space

*Performance can be improved significantly by adding additional memory.*

*A mouse is recommended, but not required.*

#### Software:

- MS DOS V5.0 or later
- Microsoft Windows V3.1 or later (running in enhanced mode)
- Microsoft Windows 95/98/NT/2000/XP for Version 3.9 or later

*The Version Control Library feature (if used) requires the Intersolv Polytron Version Control System, Version 5.0, or later.*

**Programming Executives**

Model No. 57C391

**Programming and Configuration Software  
The AutoMax Programming Executive – Version 2**

The AutoMax Programming Executive is a software tool for off-line application program development, and on-line process monitoring and control for the AutoMax System. The ReSource Programming Executive is provided on 3 1/2" floppy disks and operates on any IBM-PC compatible personal computer.

Straightforward menu displays with help screens give the user easy access to the off-line functions and on-line operations. Off-line functions allow the user to create and edit application programs and to manipulate the files that reside on a floppy or hard disk in the personal computer. The ON-LINE mode allows the user to perform various functions on-line to programmed tasks after they have been downloaded to the Processor Modules.

Off-line Functions that are available to the user and are selected directly from the main menu or sub-menus include the following:

**Edit** – Creates, changes and views application tasks. There are two editors which are automatically selected based on the type of task being edited. The Text Editor is used to edit BASIC, Control and Configuration Tasks. The PC Editor is used for PC Ladder Logic Tasks.

**Print** – Provides a hard copy listing of a selected application task. Text application tasks (BASIC, Control, Configuration) are printed immediately when selected. When Ladder Logic tasks are printed, additional descriptive information can be entered and printed. Also, during the Ladder printout, automatic documentation descriptions and cross-references are generated.

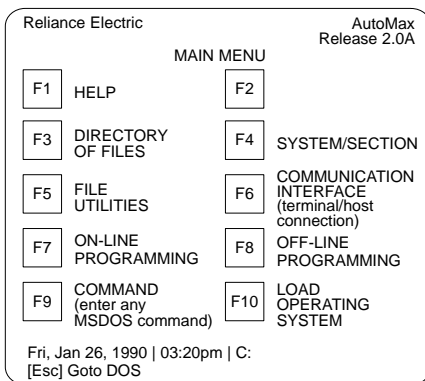

Main Menu – AutoMax Programming Executive

**Systems/Section** – Allows the user to sub-divide the total application program into sub-directories so that tasks for a particular system or subsystem (section) are conveniently grouped together.

**Communication Interface** – Causes the PC to act as a terminal if it is connected to another computer via a serial port. This function also allows software transfers between computers.

File manipulations include the ability to copy, delete or rename existing AutoMax tasks residing on disk.

**ON-LINE Programming**

An example of the ON-LINE main menu, which is encountered as the user first enters into the ON-LINE mode of operation, is shown on following page. All of the main functions available to the user are displayed on the upper portion of the screen. To select a function, the user presses the keyboard key corresponding to the highlighted portion of the desired function. A list of tasks which are currently in the AutoMax Processor Modules appears on the lower portion of the screen when the main menu is displayed. Each task name is shown in capital characters followed by the task type.

ON-LINE functions that are selected by the user from the ON-LINE Menu include the following:

**Load** – Download selected files from the programmer to AutoMax Processor Modules.

**Save** – Upload selected files from the AutoMax to the programmer. Files can be reconstructed SOURCE code. Tunable variables can also be saved separately.

**Run** – Starts one or more application tasks.

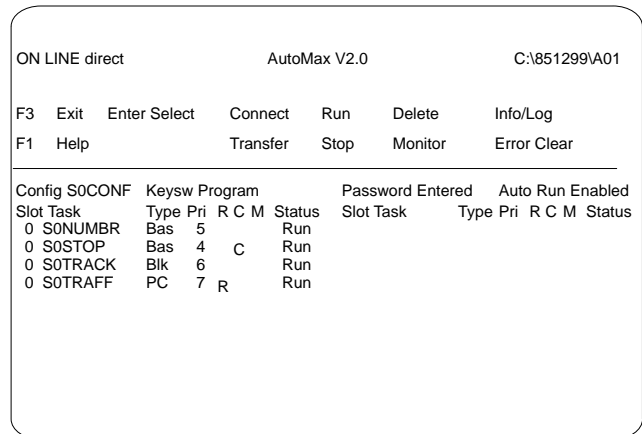

On-Line Programming Menu – AutoMax Programming Executive

**Stop** – Stops one or more application tasks.

**Delete** – Removes an application task and its data structures from a Processor Module. A task must be stopped before it can be deleted.

**Info Log** – Provides type, priority, and status information about a specific task and presents a list of associated statement run-time errors.

**Contact Reliance Renewal Parts  
at 864.284.5202.**

## Programming Executives

Model No. 57C391

---

**Clear Error** – Clears Processor Module LED fault indicator and task error logs.

**Monitor** – Permits the display and manipulation of application program variables, I/O points and registers, and ladder logic sequences.

**Variable Monitor** – Provides continuous display of the current values of user-selected variables and permits changing of variable values. The monitored variables are placed in a “variable monitor list” that will accommodate 16 entries. Variables can be displayed in decimal, hexadecimal, binary or Boolean formats. A variable can be SET to a specified value, TUNED by incrementing the value a defined amount, or FORCED to any arbitrary value.

**I/O Monitor** – Shows the state of I/O registers continuously and allows the state to be changed. The I/O Monitor differs from Variable Monitor in that the I/O registers to be displayed or changed are specified by I/O address rather than variable name. This allows monitoring of hardware I/O points independent of application software and before configuration.

**PC Monitor and Program** – Monitors the operation of a PC Task that is currently running. The user may select any sequence in the program for display on the CRT. The display indicates logic flow by reverse video. The current value of a Counter or Timer is displayed along with its present value. For a Shift Register, the current contents of the register are displayed. On-line program modifications are also available for PC tasks. Capabilities include move, insert, delete, and modify a sequence; modify a preset; force and unforce; and resequence task.

**Force** – Is used to set a variable to a specified value. Once forced, a variable value remains unchanged until it is unforced. The ability to force not only I/O points but also program variables is very useful for system checkout.

### Personal Computer Requirements Version 2

#### Hardware:

- IBM PC compatible computer
- 80286 or higher processor
- 640 K RAM
- 6 MB hard disk space

#### Software:

- MS DOS V3.1 or later

**Contact Rollanco Renewal Parts at 864.284.5202.**

**Selection Charts**

**Executives**

Executive	Description	Required Operating System	CPU	Required AutoMax Processor	Required Disk Space	Required Memory	DPS	Model Number
AutoMax Version 2 Single User Executive	<b>DISCONTINUED</b>							
AutoMax Version 2 Multiple Executive	DOS Based Programming Executive for the AutoMax DCS System - Requires purchase of 3 full executives. Manuals are extra.	DOS 3.1 or later	80286 or later (80386, 80486, etc.)	6011 or 7010 Processor	6 Megabytes	640 K	No	57C317
AutoMax Version 2 Executive Upgrade	<b>DISCONTINUED</b>							
AutoMax Version 3 Single User Executive	Windows 3.1 Based Programming Executive for AutoMax DCS System	Windows 3.1 or Windows 95/98/NT/2000/XP	80386 or later (80486, etc.) Pentium	6011 or 7010 Processor	7 Megabytes	2 Megabytes	Yes	57C610
AutoMax Version 3 Multicopy Executive	Windows 3.1 Based Programming Executive for AutoMax DCS System - Requires purchase of 3 full executives. Manuals are extra.	Windows 3.1 or Windows 95/98/NT/2000/XP	80386 or later (80486, etc.)	6011 or 7010 Processor	7 Megabytes	2 Megabytes	Yes	57C611
AutoMax Version 3 Executive Upgrade	Windows 3.1 Based Programming Executive for AutoMax DCS System - Updates earlier versions to latest Version 3 Release.	Windows 3.1 or Windows 95/98/NT/2000/XP	80386 or later (80486, etc.) Pentium	6011 or 7010 Processor	7 Megabytes	2 Megabytes	Yes	57C611
AutoMax Version 4 Executive	Windows 95/98 Based Programming Executive for AutoMax DCS System	Windows 95/98/NT/2000/XP	Pentium	6011, 7010, or PC3000 Processor	18 Megabytes	16 Megabytes	Yes	57C610
AutoMax Version 4 Multicopy Executive	Windows 95/98 Based Programming Executive for AutoMax DCS System - Requires purchase of 3 full executives. Manuals are extra.	Windows 95/98/NT/2000/XP	Pentium	6011, 7010, or PC3000 Processor	18 Megabytes	16 Megabytes	Yes	57C611
AutoMax Version 4 Executive Upgrade	Windows 95/98 Based Programming Executive for AutoMax DCS System - Updates earlier versions to latest Version 4 Release.	Windows 95/98/NT/2000/XP	Pentium	6011, 7010, or PC3000 Processor	18 Megabytes	16 Megabytes	Yes	57C611

**Selection Charts**

**Extra Documentation Sets**

Model Number	Description
57C321	<b>DISCONTINUED</b>
57C322	AutoMax V3 Documentation (includes J-3656, J2-3049, J2-3080, J2-3006, J2-3007, J2-3068)
57C323	AutoMax V4 Documentation (includes J-3656, J2-3066, J2-3007, J2-3068, J2-3104, J2-3092, J2-3096)
S-3000	SD3000/SF3000 Documentation
S-3001	SA3000 Documentation
S-3002	SA500 Documentation
S-3003	SB3000 Documentation
57C322, and 57C323 provide full sets of documentation for the AutoMax V2, AutoMax V3, and AutoMax V4 respectively. Individual volumes of these materials may be ordered separately. Program executives 57C391, 57C610, and 57C605 include one full set of documentation.	

To review current released versions, go to [www.reliance.com/automax](http://www.reliance.com/automax).

**AutoMax DPS Software Options–  
Single-User Version**

Model Number	Description
57C651	SD3000 DPS DC Drive Software
57C652	SF3000 DPS Motor-Generator/Field Control Software
57C653	SA3000 DPS AC Drive Software
57C654	SA500 DPS Brushless DC Control Software
57C655	SB3000 DPS Synchronous Rectifier Control Software
57C656	VZ3000 DPS Positioning Drive Software
57C657	SA 3100 DPS AC Drive Software
57C650	Shared-user license for AutoMax DPS

DPS software is used to program the UDC Module and PMI processor in Distributed Power Systems. It is used in conjunction with the AutoMax full or runtime versions of software Executive. Licensing for DPS software options is the same as for the executive software – one copy per personal computer. Each DPS software option includes the manual for that particular drive.

If DPS software is used on a file server for multiple users, 57C650 is required in addition to the options above.

The 57C650 license allows 5 users to access each of the DPS software options which are installed on the file server.

**Note on License Agreement**

Single-user versions of Programming Executive software are licensed for use on a single central processing unit (personal computer). Shared-user versions may be installed on a file server for simultaneous access by a limited number of users. For a full copy of the license agreement request ZJ-117-1.

**Contact the Local Drive Solutions Center at 440.646.7202.**



## Operator Interface

---

A wide variety of operator interface options, from RediPANEL to PanelView and RSVIEW 32, are available to provide you the right information at the right time on an operator interface that best suits the demand of your application. You can choose from a number of network options like Allen-Bradley's Remote I/O network, Data Highway Plus, ControlNet and DeviceNet to provide high speed connectivity between AutoMax and operator interface products from Allen-Bradley.

Reliance Electric prior to 1995 sold a series of operator interface terminals under the ShopMax and PanelMax labels. One feature that many customers used was the ability to connect these terminals directly onto the AutoMax DCS-Net network using 61C155 Network Interface Card.

These products have been discontinued by the third party manufacturing company that supplied us these terminals. The connector (61C155) required to connect these terminals directly onto an AutoMax DCS-Net network is also obsolete. In some cases, existing units can be repaired. Other than repair, there are no available direct replacements that can be used without some modification to your control system.

There are several newer products available that are functional replacements for the ShopMax or PanelMax terminal. The choice of replacement may be based on the way the terminal needs to connect to the AutoMax/DCS5000 controller:

- If the AutoMax DCS-Net connection is to be maintained, the suggested replacement would be an industrial computer running RSView32. There are interface cards and drivers available from one of our Encompass Partner (SST) to connect the DCSNet to RSView32. This will require that the screens and messages in the operator terminal be pre-programmed into RSView.
- The A-B PanelView products offer a good set of solutions if a different interface card is used in the AutoMax system. Any of the PanelView products can be connected to the AutoMax via either the A-B Remote I/O network (using the 57C443A card) or Data Highway Plus (using the 57C442 card). This conversion will require some program changes in the AutoMax for the new network. Rockwell Automation's Technical Support Group can assist you in converting the graphic screens into PanelView products.

Global Manufacturing Services Business (GMS) can assist you in the conversion from your ShopMax/PanelMax operator stations to one of the options above. For more information on all other conversion services options, contact your local Rockwell Automation sales office or authorized distributor or email [raprogramconversion@ra.rockwell.com](mailto:raprogramconversion@ra.rockwell.com).

## Notes

---

**Third Party Cards****Woodhead**

SST X-Link Communication Gateways .....	6-2
SST PICS Simulation for Windows .....	6-2
SST VME Interface Card for Reliance AutoMax DCS/RIO .....	6-3
SST Profibus Module for Reliance AutoMax.....	6-3
SST Reliance AutoMax DCS/RIO Module for GE Fanuc Series 90-70.....	6-3
SST DeviceNet Module for Reliance AutoMax .....	6-4
SST OPC and DDE Servers for Reliance AutoMax and AutoMate.....	6-4
SST PCI Interface Card for Reliance AutoMax DCS/RIO .....	6-4

**VMR Software**

MaxView Trending .....	6-5
Variable Organizer.....	6-5
MaxTools .....	6-6
Block Task Viewer .....	6-6

**Delta Computer Systems, Inc.**

Four Axis Hydraulic Servo Card.....	6-7
-------------------------------------	-----

**Weed Fiber-Optics**

EOTEC Modem .....	6-7
-------------------	-----

**Systems Integrators and Controls**

Multibus Frequency Output Module .....	6-8
--	-----

**Quest Technical Solutions**

Automation Network X-change (AN-X) .....	6-9
--	-----

**The information contained herein is solely for reference purposes as a convenience to our customers. Please contact the respective manufacturer for product specification, pricing, and ordering information.**



DISTRIBUTED CONTROL SYSTEM

## Woodhead

### SST X-Link™

---

SST's X-Link™ allows you to create a bridge between dissimilar network protocols. With a large and expanding library of network protocol drivers, X-Link is capable of creating over 2000 gateway combinations without programming. Simply download the appropriate network driver combination and set up data mappings using a fill-in-the-blank interface. Applications include creating a firewall, bridging networks, integrating remote installations, a device or HMI/SCADA system, and using as a data concentrator/SCADA front-end.

For the AutoMax family, X-Link connects DCS (master or slave) to:

- Allen-Bradley
  - Data Highway
  - Data Highway Plus
  - DH485
  - 1771 Remote I/O
  - DF-1
  - Ethernet
- ControlNet
- DeviceNet
- Reliance AutoMate R-Net
- Reliance AutoMate RIO
- Reliance AutoMax DCS

#### For more information contact:

##### In North America:

50 Northland Road  
Waterloo, ON, Canada  
N2V 1N3  
Phone: 519-725-5136  
Fax: 519-725-1515

##### In Japan/Korea:

Landmark Tower 4309  
Minatomirai 2-2-1, Nishi-ku  
Yokohama-city 220-8143  
Japan  
Phone: + 81-45-224-3560  
Fax: +81-45-224-3561

##### In Europe:

43, rue Mazagran  
76320 Caudebec-les-Elbeuf  
France  
Phone: 33 (0)2 32 96 04 20  
Fax: 33 (0)2 32 96 04 21

##### In Asia-Pacific:

8 Chia Ping Road #05-09/10  
JTC Flatted Factory  
Jurong Town 619973  
Singapore  
Phone: +65-261-6533  
Fax: +65-261-3588

##### In United Kingdom:

Factory No. 9  
Rassau Industrial Estate Ebbw Vale  
Wales, Gwent NP23 5SD  
United Kingdom  
Phone: 44 1495 350436  
Fax: 44 1495 350877

Email: [sales@mySST.com](mailto:sales@mySST.com)  
Web Site: [www.mySST.com](http://www.mySST.com)

---

## SST PICS Simulation Software

SST PICS Pro I/O simulation software simulates real-world systems and machines controlled by DCS, PLC, and PC Control systems. The entire system can be tested (communication, sequencing/interlocking, HMI/SCADA, alarms), all emergency faults can be verified, and operator trained, without modifying your system. Fifteen years and over 1,000 customers have proven that PICS saves times and money, reduces technical and scheduling risks, minimized process downtime, and greatly enhances operator training.

PICS Simulation supports Wonderware DDE I/O Servers as PICS drivers. Use of DDE Servers as drivers for PICS provides the ability to simulate with the AutoMate (serial) and AutoMax (PC Link).

For further information, see address above.

**Woodhead****SST VME Interface Card for Reliance AutoMax DCS/RIO**

---

The SST 5136-REL-VME interface card provides communication between a VMEbus computer and Reliance AutoMax DCS / RIO networks. The card uses a shared memory interface with the host computer. All card data is available to the host simply by reading from or writing to this shared memory.

**Features include:**

- Operates on Reliance AutoMax DCS network as a master or slave
- Can monitor (passive) or emulate (active) one or more I/O drops on a Reliance AutoMax RIO network
- Open card interface design eases driver development and allows portability to different VME hosts and operating systems
- Includes sample "C" programs for AutoMax DCS and RIO applications
- Diagnostic LEDs for quick verification of card

For further information, see address on page 6-2.

**SST Profibus Module for Reliance AutoMax**

---

The SST Profibus Module (part number SST-PFB-REL) connects your Reliance AutoMax PLC to Profibus DP. Applications include scanning or emulating Profibus I/O.

**Features include:**

- Supports all standard Profibus baud rates (up to 12 Mbaud)
- Simultaneous operation of Profibus DP Master, DP Slave
- Extremely fast scan rate for a DP Master, 6000 I/O in 1ms
- Example Reliance PLC code included

For further information, see address on page 6-2.

**SST Reliance AutoMax DCS/RIO Module for GE Fanuc Series 90-70**

---

The SST Reliance AutoMax DCS/RIO Module (part number SST-REL-GE) connects your GE Fanuc Series 90-70 programmable controller to Reliance AutoMax DCS or Remote I/O network. Applications include data acquisition, network monitoring and peer-to-peer communications.

**Features include:**

- Operates on Reliance AutoMax DCS network as a master or slave
- Module can monitor (passive) or emulate (active) one or more drops on a Reliance AutoMax remote I/O network
- Access the module using VME\_RD and VME\_WRT commands in the GE 90-70
- Includes sample GE 90-70 applications
- Diagnostic LEDs for quick verification of module operations
- Two BNC connectors included for daisy chain configurations
- Software watchdog for improved reliability

For further information, see address on page 6-2.



DISTRIBUTED CONTROL SYSTEM

## Woodhead

### SST DeviceNet Module for Reliance AutoMax

---

The SST DeviceNet Module (part number SST-DNP-REL) connects your Reliance AutoMax PLC to DeviceNet. Applications include scanning or emulating DeviceNet I/O.

**Features include:**

- Two independent DeviceNet connections
- On board flash for auto-booting
- Entire DeviceNet Protocol is implemented on the module
- UCMM capable, Group 1, 2 and 3 dynamic connections supported
- Simultaneous execution of Group 2 Client (master) and Server (slave) operation
- All DeviceNet standard baud rates supported: 125, 250 and 500 Kbaud

For further information, see address on page 6-2.

## Woodhead

### SST OPC and DDE Servers for Reliance AutoMax and AutoMate

---

SST OPC and DDE Servers provide connectivity between a software application using the OPC or DDE Client with the Reliance AutoMax DCS or Reliance AutoMate R-Net networks.

For further information, see address on page 6-2.

## Woodhead

### SST PCI Interface Card for Reliance AutoMax DCS/RIO

---

The SST Reliance AutoMax PCI interface card (part number 5136-RE2-PCI) allows a PCI bus computer to function as a drop on the AutoMax DCS-NET and Remote I/O networks, providing for a direct exchange of data with an AutoMax control system.

**Features include:**

- Allows a PCI computer to function as a drop on either the Reliance DCS-NET or Remote I/O network
- Includes Network Communications and Remote I/O Software
- Provides high-speed link, avoiding bottleneck of RS232 serial connections

For further information, see address on page 6-2.

**VMR Software**  
**MaxView Trending**

- Monitor and trend any variable: locals, commons, tunables, network, etc.
- No configuration or mapping required – setup and trend within 5 minutes
- Export 24+ hours of data for analysis in a spreadsheet or database

**For more information contact:**

VMR Software, a division of VMR Products, Inc.  
Edmonds, WA 98020  
Phone: (425) 774-2483  
Email: sales@vmrsoftware.com  
Web: <http://www.vmrsoftware.com>  
P.O. Box 1463  
Fax: (425) 672-7955

**VMR Software**  
**Variable Organizer**

- Read, edit, import and build monitor files (.\$MV files) offline or online
- Familiar Windows Explorer format and functions (drag and drop, copy, paste, etc.)
- No data entry required- Variable Organizer reads your databases
- Re-sequence variables when online for side-by-side comparison

For more information see address above

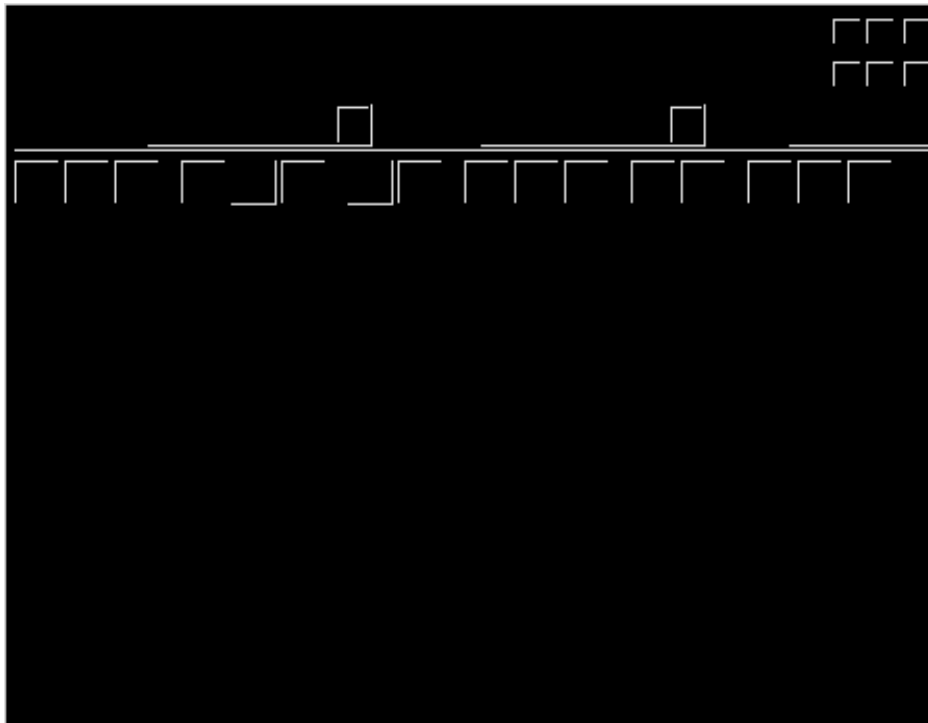

## VMR Software

### MaxTools

- Our most popular product– used in 40+ states/provinces and 30+ countries
- Graphical tool to generate control block diagrams and/or source code (.BLK files)
- Build control block diagrams 4 to 5 times faster (compared to CAD)
- Drawings are 100% accurate– no typos, mis-drawn lines, omitted variables, etc.
- The official control block editor of Rockwell Automation
- Works with Windows 95/98/NT/2000 and XP

#### For more information:

VMR Software, a division of VMR Products, Inc.  
Edmonds, WA 98020  
Phone: (425) 774-2483  
Email: sales@vmrsoftware.com  
Web: <http://www.vmrsoftware.com>  
P.O. Box 1463  
Fax: (425) 672-7955

## VMR Software

### Block Task Viewer

- Online tool that displays and updates variable values on your control block diagrams
- Works with MaxTools drawings
- Easy to setup and use
- Excellent education & instructional tool

For more information see address above

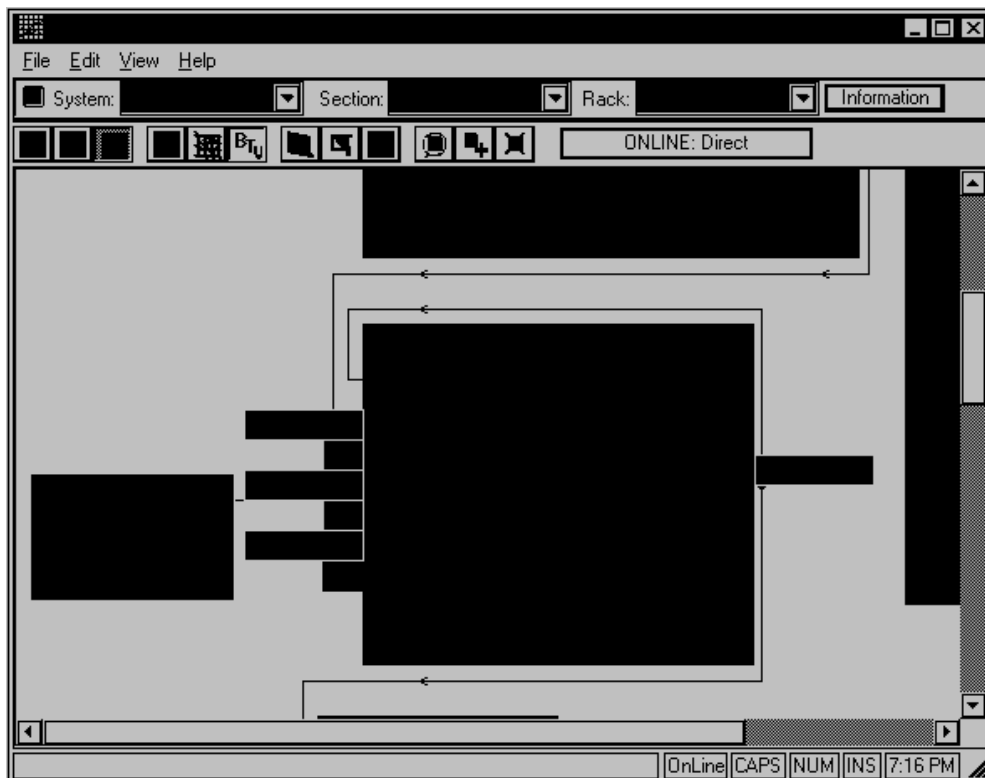



**AUTOMAX**<sup>®</sup>

DISTRIBUTED CONTROL SYSTEM

**Delta Computer Systems, Inc.**  
Four Axis Hydraulic Servo Card (Multibus 1)**MC 186/40 Four axis Servo Motion Controller**

The MC 186/40 motion subsystem is a high performance axis controller for use with Magnetostrictive Displacement transducers (Balluff, Gemco, Temposonics, etc.). The Multibus 1 bus-based controller provides four channels of optically isolated position control that is used with hydraulic cylinders and servo motors. These controllers close the position loop every millisecond.

**For more information contact:**

Delta Computer Systems, Inc.  
11719 NE 95th St. Ste. D  
Vancouver, WA 98682-2444  
Phone: (360) 254-8688  
FAX: (360) 254-5435  
Web: [www.deltamotion.com](http://www.deltamotion.com)  
Email: [sales@deltamotion.com](mailto:sales@deltamotion.com)

**MC 186/40-TA Four axis Servo Position/Pressure Motion Controller**

The MC 186/40-TA motion subsystem is a high performance axis controller for use with Magnetostrictive Displacement transducers (Balluff, Gemco, Temposonics, etc.) and analog pressure transducers. The Multibus 1 bus-based controller provides four channels of optically isolated position/pressure control that is used with hydraulic cylinders and servo motors. These controllers close the position loop and a pressure loop every millisecond with seamless transfer between the two.

**RCM 100 Family of Motion Controllers**

Delta Computer Systems manufactures high performance Motion Controller products for 1 to 8 axis servo-hydraulic and servo-motor applications. Applications typically require precise position, velocity, and pressure control. These controllers can close the loop every millisecond. Position and Pressure control is seamlessly transferred between the two loops. The RCM features open fieldbus communications, Ethernet I/P, PROFIBUS-DP, Modbus Plus, Serial and Digital I/O (25+ protocols). Connect I/O with Mix and Match Transducer modules allowing more than 500 configurations for Analog, MDT, Quadrature, Digital, SSI, Stepper and others. Use powerful RMCW in software to easily set up, tune, diagnostic and programming for your applications or to communicate easily with the AutoMax, Computer, or System.

**Weed Fiber-Optics**  
EOTEC Modem

The Series 6000 fiber optic modem provides a reliable communication link between PLCs or PLC/Remote I/O racks. Modular design allows maximum flexibility in designing a system to interface with all standard PLC devices, serial interfaces, and other fiber optic modems. Options include self-healing ring for critical applications and single-fiber communication for use with fiber optic slip rings.

**For more information contact:**

Weed Fiber-Optics  
707 Jeffrey Way  
P.O. Box 300  
Round Rock, Texas 78680-0300  
Phone: (512) 434-2850 FAX: (512) 434-2851  
Web: <http://www.weedinstrument.com>  
E-Mail: [fiberop@weedinstrument.com](mailto:fiberop@weedinstrument.com)

## Systems Integrators and Controls

### Multibus Frequency Output Module Product: Model IDC400

---

Custom built frequency output card that fits Reliance AutoMate 30/40 and DCS racks.

#### Function:

The Multibus Frequency Output Module supplies variable frequency pulse trains to six (6) independent devices. Pulse trains can serve as set points, control signals, or references for variable speed drives and other digitally controlled equipment. Pulse trains are more accurate, have better noise immunity, and are more effective over longer distances than are common analog signals. Outputs are software controlled over eight (8) ranges up to a maximum output of 500k Hz.

#### Features:

- 6 selectable channels.
- 8 selectable frequency ranges per channel.
- Frequency software adjustable up to 500k Hz. 16 bit resolution.
- Internal or external reference frequency source.
- Power supplied by host.
- Transformer output isolation. 20 or 24 bit Multibus addressing.
- Full AutoMate Multibus checkerboard diagnostic support.
- DCS 5000 compatibility.
- Standard Locout blocks used to access the card.

Other products available through Industrial Design for use with the Reliance Electric AutoMate include PC3125, DLM2000, IDC203, IDC207, IDC429R, ID-EPCC, A35DOC.

#### For more information:

Systems Integrators and Controls  
11205 McMullen Road  
Riverview, FL 33569  
Voice 813-671-0231  
Fax 813-671-0341  
Email: [systemsinc@earthlink.net](mailto:systemsinc@earthlink.net)

## Quest Technical Solutions

---

### **AN-X-DCSNet Ethernet to AutoMax DCSNet Bridge**

- Connects any computer with an Ethernet port to an AutoMax DCS network.
- Supports AutoMax programming software.
- Acts as a DCS master or slave.
- Supports scheduled connections with a ControlLogix processor over Ethernet for exchange of DCS data.
- Supports direct AN-X to AN-X communication to transfer data from one DCS network to another over Ethernet.
- Web interface for configuration and monitoring.

### **For more information contact:**

Quest Technical Solutions  
4110 Mourning Dove Court  
Melbourne FL 32934  
Phone: 321 757-8483  
website: [www.qtsi.biz](http://www.qtsi.biz)  
email: [sales@qtsi.biz](mailto:sales@qtsi.biz)

### **AN-X-AMXRIO AutoMax Remote I/O Master**

- Acts as a master on an AutoMax remote I/O network.
- Supports scheduled connections with a ControlLogix processor over Ethernet for exchange of I/O data.
- Web interface for configuration and monitoring.

### **AN-X-AMXCAPT Frame Capture Tool**

- Capture, store and analyze network data on a Reliance AutoMax DCS or remote I/O network.
- Examine the behavior of all drops, verify network data and timing, locate network errors and troubleshoot problems with the network and with the process.
- Does not occupy a drop on the network or affect existing network traffic in any way.

**Rockwell Automation Support**

---

Training .....	7-2
Expert Systems / Diagnostic Tools .....	7-3
GMS Westerville Operations .....	7-4
I/O Saver Rail I/O to PLC Interface .....	7-5
Rockwell Automation Drive Systems .....	7-7
Remote Access Dail-In Kits and Tutorial .....	7-12
Reliance Phone Numbers for Technical Information .....	7-13
Websites .....	7-13

## Training

---

### Industrial Controls Training Classes

A variety of courses are available on your Industrial Control Products. These courses are instructor led and incorporate lecture and hands-on using the actual equipment configured for optimum learning.

Classes are scheduled throughout the year at various Rockwell Automation facilities.

In addition, classes can be conducted at the customer site, and customized to incorporate their needs. Introductory, maintenance, programming, operator and system specific options are available.

### Ordering Information

Description	Cat. No.
AC/DC Drives and Introduction to AutoMax	RE0505
AutoMax Maintenance and Troubleshooting	RE0520
AutoMax DC Drive – Distributed Power System (DPS)	RE0521
AutoMax AC Drive – Distributed Power System (DPS) SA500/SA3000	RE0526
AutoMax AC Drive – Distributed Power System (DPS) SA3100 & RGU/NRM	RE0530
AutoMax Programming Fundamentals	RE0523
AutoMax Intermediate Programming	RE0528
AutoMax Advanced Programming	RE0525
AutoMax Drives Programming	RE0524
SIGMA Universal Process Monitor (UPM) and Universal Operator Interface (UOI)	RE0527

For more information, contact your local Rockwell Automation sales/service office.

## Expert Systems/Diagnostic Tools

### Intelligent Troubleshooting Assistant Series

Part Number	Description
ES1030	DPS-DC Intelligent Troubleshooting Assistant
ES1040	SA3000 Intelligent Troubleshooting Assistant

The Intelligent Troubleshooting Assistant (ITA) provides users with intelligent stand-alone, off-line **troubleshooting assistance** 24 hours a day, 365 days a year. The ITA series uses the latest Expert System technology, called Case-based Reasoning. The Case-based Reasoning software used in the ITA's is a diagnostic procedure that involves asking questions to narrow the field of investigation and arrive at a practical solution. It stores experiences as "cases" and then retrieves that information and applies it as a solution to current problems. The ITA series contains the experience of our technical support staff.

Each of the ITA modules are available on 3<sup>1</sup>/<sub>2</sub>" floppy disks and operates on any IBM-PC AT or compatible personal computer with a 80386 or faster CPU, 4MB of memory, a hard disk, windows-compatible mouse and a VGA or higher (256 colors) resolution video card and monitor. The ITA requires either MicroSoft Windows 95 or Windows version 3.1 or higher.

### Diagnostic Expert System

Part Number	Description
ES1000A	AutoMax/DCS Diagnostic Expert System, 3.5" Disk only
ES1010	CSI Diagnostic Expert System, 3.5" and 5.25" Disks
ES1020	MaxPak III Diagnostic Expert System, 3.5" Disk only

The Diagnostic Expert Systems are expert systems designed for quick, efficient troubleshooting of Reliance AutoMax/DCS, CSI or MaxPak III equipment. This diagnostic system is a storehouse of expertise that enables your maintenance people to tap the knowledge of Reliance experts without a service call.

The Diagnostic Expert Systems operate on the ReSource-PC programmer or any other IBM-PC AT or XT compatible personal computer with 640K RAM, a hard disk, and Version 3.1 or later MS-DOS Operating System. The Diagnostic Expert Systems are DOS-based.

For more information, contact your local Rockwell Automation sales/service office.

## GMS Westerville Operations

---

### Rockwell Automation Manufacturing/Remanufacturing Westerville Operations

Rockwell Automation is the best source of service for all of your Rockwell Automation electronic equipment. As a manufacturer of sophisticated electronic products, Rockwell Automation transfers its highly respected manufacturing standards, technical knowledge, and component parts sourcing to the remanufacturing of your electronic equipment. Each unit will be inspected, tested and upgraded to the latest design specifications, using genuine Rockwell Automation factory approved replacement parts. All remanufacturing is performed at an ISO 9002 certified facility.

The same high standards and specifications used to manufacture new Rockwell Automation electronic products are applied to all remanufactured components. This comprehensive process assures optimum performance and service life.

### Other Services Available

- Remanufacturing/Repair Services
- Rental units

### World Class Remanufacturing

Your component will be serviced in a static-free environment to ensure absolute electronic integrity. The Reliance Electric electronic remanufacturing facility is an ISO 9002 certified facility.

### Upgraded to the Latest Revision

When your component is remanufactured, it is updated to the latest design standard for Reliance Electric equipment. It's an extra step that helps assure you will receive maximum value from our products.

### Warranty

We stand behind our remanufacturing process with a warranty that covers your entire unit for 12 months from the date of shipment.

### Diagnostic Charges - Released Orders for Remanufacture

Orders that are authorized to proceed (purchase order issued) upon receipt will be processed immediately. If no problem is found, a \$200.00 net, per line item, diagnostic charge will apply.

### Delivery

Normal delivery is 5-7 working days, upon receipt of the item at our remanufacturing facility. This delivery is based upon Reliance Electric having a released order (purchase order) authorizing the item to be remanufactured.

### Breakdown Service

Should you require breakdown service, a 25% charge will apply. This charge enables us to service your equipment on an expedited basis. We remanufacture all parts, unless specifically instructed otherwise. To request breakdown service, advise your Reliance Electric representative, and clearly mark "Breakdown" on your purchase order and packing slip. If it appears the remanufacturing of your item will take more than 48 hours, (longer for drives) from the time the item is received at our repair facility to the time it is shipped, you will be notified by telephone of the expected delivery and the breakdown charge will be waived. Breakdown orders are returned by air freight.

### Ordering Procedure

To place an order simply, enclose your purchase order with your material and send to your local Reliance Service Center, Authorized Distributor or the Digital Products Service Center.

If you need a price ask us to "notify price upon receipt" on your purchase order or call us before you send it in. All units received will be quoted within 48 hours of receipt.

Rockwell Automation  
Manufacturing/Remanufacturing  
Global Manufacturing Solutions  
8333G Green Meadows Drive North  
Westerville, Ohio 43081  
Telephone 800-669-6119, 740-548-5733  
Facsimile 740-657-2212

## I/O Saver Rail I/O to PLC Interface

Model No. 61C326



### Benefits

- Easy-to-use I/O conversion process
- Integration of Reliance Electric and Allen-Bradley control systems
- Significant cost savings over new I/O systems

### Incorporate the features of an Allen-Bradley programmable controller without installing new I/O

The I/O Saver Rail Interface module lets you control field devices that are connected to a Reliance AutoMate<sup>®</sup> Rail I/O via an Allen-Bradley remote network. The I/O Saver module resides as an adapter on the Allen-Bradley Remote I/O link. You can convert your Rail I/O system into an Allen-Bradley remote I/O link by simply replacing the AutoMate Remote I/O Heads with I/O Saver modules. There is no need to replace I/O modules and field wiring.

For further information call 1-440-646-6650.

### Control AutoMate Rail I/O with a PLC-5 Processor

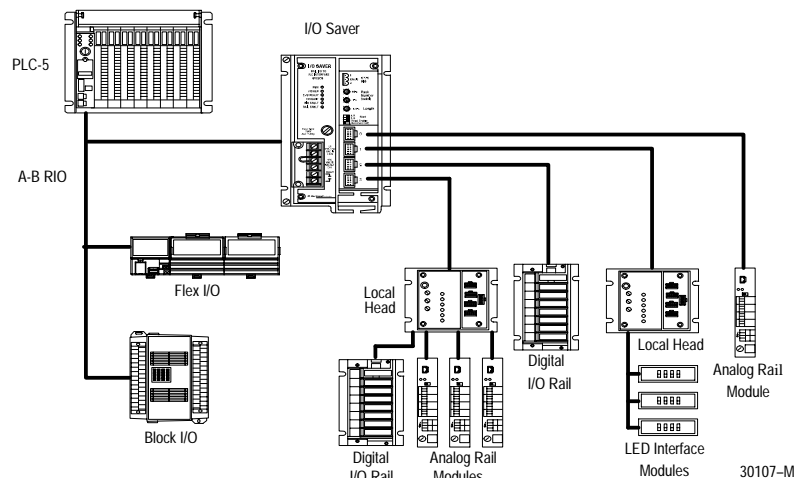

### Control AutoMate Rail I/O with an AutoMax Processor over an Allen-Bradley Remote I/O Link

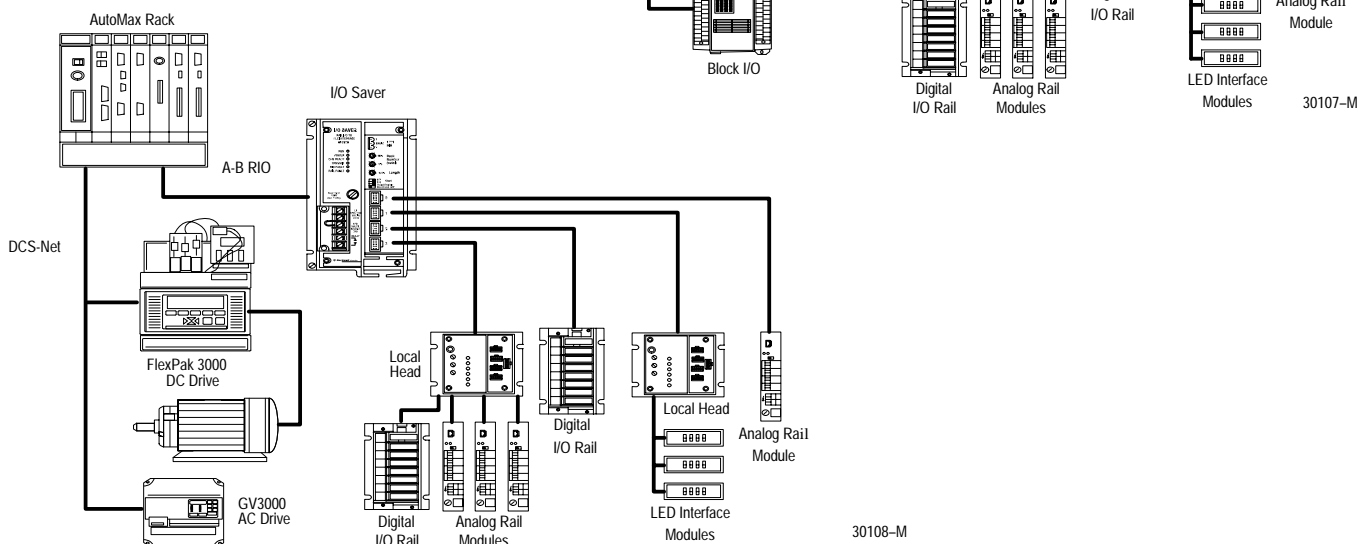





## Notes

---

## Rockwell Automation Drive Systems

---

**“When faced with tough migration, replacement or connectivity questions, call your nearest Local Drive Solutions Center for help.”**

Regional engineering and manufacturing facilities enable us to provide local drive solutions that range from evaluation of your process requirements through commissioning of the new system.

World class expertise in web handling, coordinated drive applications and machine sequencing.

Projects include hardware and software platform migration and new systems.

### Local Drive Solutions Contacts Directory

#### **New England**

Ph: 508.485.4447  
Fax: 508.485.5059  
Boston, MA

#### **Southeast**

Ph: 770.277.0277  
Fax: 770.682.6491  
Atlanta, GA

#### **Gulf Coast**

Ph: 281.233.0300  
Fax: 281.233.0101  
Houston, TX

#### **West Coast**

Ph: 626.969.7647  
Fax: 626.334.8320  
Los Angeles, CA

#### **Eastern**

Ph: 732.225.1360 x110  
Fax: 732.225.7833  
Edison, NJ

#### **Carolinas**

Ph: 704.525.1455  
Fax: 704.525.9025  
Charlotte, NC

#### **Midwest**

Ph: 630.860.1090  
Fax: 630.787.0309  
Chicago, IL

#### **St. Louis, MO**

Ph: 314.770.0168  
Fax: 314.770.0268  
St. Louis, MO

#### **Ohio Valley**

Ph: 513.943.1145  
Fax: 513.943.7438  
Cincinnati, OH

#### **Great Lakes**

Ph: 440.604.8421  
Fax: 440.604.8437  
Cleveland, OH

#### **North Central**

Ph: 651.633.8015  
Fax: 651.633.7181  
Minneapolis, MN

#### **Drive Systems Headquarters**

Ph: 262.512.8636  
Fax: 262.513.8673

### Summary

Rockwell Automation Drive Systems controller products are intended to be used and engineered by the Drive Systems Business Units and select Integrator Partners.

For specific technical assistance on any Drive Systems product, contact your local Rockwell Automation Support office.

## Rockwell Automation Drive Systems SIGMA Software System

SIGMA is a unique and flexible operator interface and maintenance tool designed to complement an AutoMax based control system. The SIGMA software runs on an IBM compatible Pentium class personal computer and is made up of two parts: the UPM (Universal Process Monitor) and the UOI (Universal Operator Interface). These two options can be sold separately or together, the SIGMA Kernel data acquisition system operates in Intel's real time operating system iRMX. The iRMX operating system is a multitasking operating system which ensures no data will be lost during operator actions.

The Universal Operator Interface takes advantage of a library of standard screens or incorporates custom screens to provide process control and monitoring. Screens are built using Visual Basic or other Windows software packages which support DDE (Dynamic Data Exchange) and DLL (Dynamic Link Library).

The Universal Process Monitor is a powerful monitor and troubleshooting tool. It will replace paper chart recorders with computerized displays. Operations, maintenance and engineering personnel may inspect trended data at their convenience. Up to four variables can be displayed at any one time, but hundreds of variables may be continuously monitored (up to 18 times a second) and stored in a rolling 48 hour window. This provides the advantage of viewing only the small number of variables of interest from correlation of variables are of interest, they can be quickly be called from the data bank.

### Availability

See page 7-7

The SIGMA is available as part of a value added solution through the Drive Systems business. Contact Local Drive Solution Centers Support Group-Great Lakes.

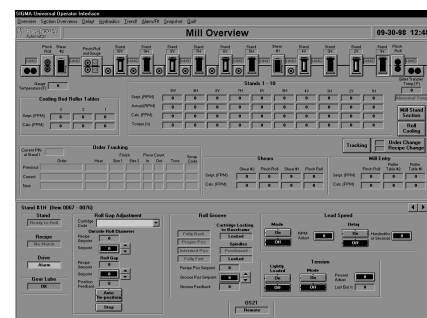
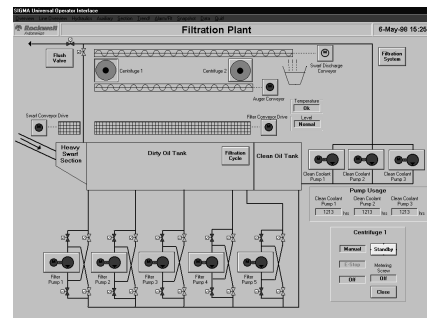
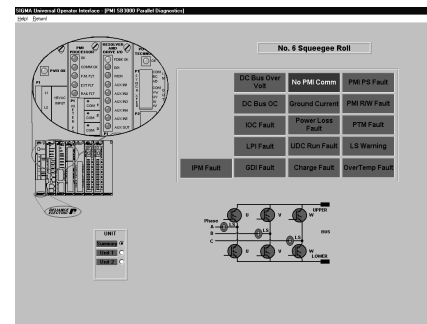
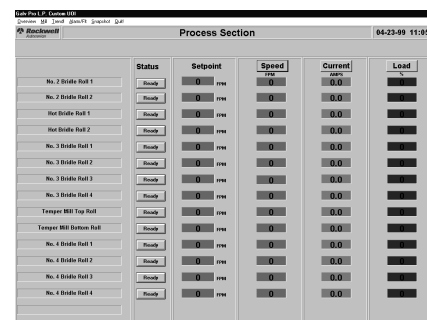
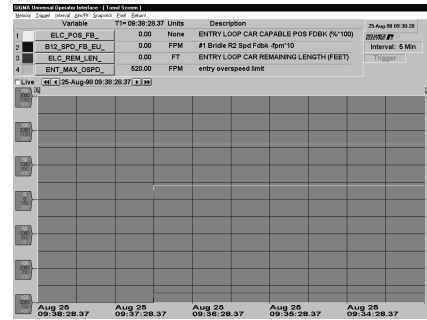

**Rockwell Automation Drive Systems****Model No. 56AMXN****56AMXN AutoMax Network and AutoMax Remote I/O Module**

The traditional Reliance Electric Systems solution is based on an AutoMax controller and architecture. DCSNet is the main communications, data, and control network or “backbone”. AutoMax Remote I/O is the Remote I/O architecture to network devices such as I/O and MMI or HMI operator stations (see Section 2 for details).

The 56AMXN module connects a Rockwell Automation ControlLogix back plane to an AutoMax DCS network or to an AutoMax Remote I/O network.

The 56AMXN is configured in RSLogix 5000 as a “generic” module. The module supports scheduled data up to 250 words of input, 248 words of output, and 250 words of status data. The module supports RPIs from .2 to 750ms.

**As a DCSNet “Master”, the 56AMXN module:**

- Scans up to 55 drops with 32 words in and 32 words out per drop.
- Transmits 8 words of global broadcast data every 2.8ms.
- Maintains standard drop 0 diagnostic counters.

**As a DCSNet slave, the 56AMXN module:**

- Acts as any drop number from 1 to 55, with drop depth from 1 to 55 (“active drops”).
- Monitors input and output data on other drops on the network (“monitored drops”).

**As a Remote I/O master, the 56AMXN module:**

- Scans up to 7 drops, with up to 248 words of output data and 250 words of input data.
- Maintains standard diagnostic counters.

**56AMXN Hardware Features**

- The module firmware can be updated with Rockwell Automation ControlFlash software.
- Switches to set the mode of operation (DCS master or slave, RIO).
- Status LED to indicate the state of the AutoMax network, ControlLogix connection and module health.
- 4-character display to indicate state and display error messages.
- 9-pin D-connector to connect to a Reliance passive tap.

**Gateway**

In DCSNet master or slave mode, the 56AMXN module can obtain the transmit data on any drop from another 56AMXN module. This allows data to be mapped from one physical DCS network to another without the intervention of a ControlLogix processor. The data may be accessed from other gateway type modules in the Logix back plane such as Ethernet, ControlNet and Data Highway Plus. No ControlLogix processor is required.

**CIP Routing**

In DCS master or slave mode, the 56AMXN module can route AutoMax programming messages from RSLinx which have been routed to the module and forward them out to drops on the DCS network. This allows AutoMax programming software to use RSLinx and full CIP routing to program AutoMax processors (Requires “Command Central” driver).

*Note that any data on DCSNet can be read or written using MSG functions in Ladder logic. The 250/248/250 word restriction applies only to the amount of scheduled data you can map into the ControlLogix processor.*

**Utilities Supplied**

The 56AMXN module comes with the following 32-bit Windows applications (95/98/ME/NT/2000). These utilities communicate with the module using RSLinx. They require RSLinx OEM or above.

**56AMxnDcsCfg to configure DCS master or slave operation.**

- Displays the network as a “tree”. You can browse the online network and automatically add and drops present to the tree.
- Drag and drop broadcast data, drop 0 diagnostic counters, or drop 1-55 drop data to map them into ControlLogix memory.
- Export tags that can be imported into your RSLogix 5000 program.

**56AMxnRioCfg to configure Remote I/O master operation.**

- Reads the online network and assigns ControlLogix registers to the data found.
- Stores the configuration into flash memory on the module.
- Exports tags that you import into the RSLogix 5000 program to access the Remote I/O data.

**56AMxnMon for monitoring and maintenance of the 56AMXN module.**

- Displays raw data for any OCS drop, including drop 0.
- Displays raw data mapped into the ControlLogix scheduled data areas.
- Displays the active drop list.
- Displays AutoMax and ControlLogix back plane diagnostic counters.
- Displays the debug-log - messages from the processor on the 56AMXN that show its internal state of operation, indicate error conditions, etc.

**Environment**

Temperature	Operating Ambient: 0°C – 55°C
	Non-operating: -10°C – 85°C
Relative Humidity	Operating: 5 to 95%, 0°C – 55°C non-condensing
	Non-operating: 5 to 95%, 0°C – 85°C non-condensing
Vibration	Equal to ControlLogix Modules
Altitude	2000 meters above sea level maximum

**Availability**

See page 7-7	The 56AMXN is available as part of a value added solution through the Drive Systems business or your Local Drive Solution Centers.
--------------	--

## Rockwell Automation Drive Systems

### Command Central

---

#### 419441-2R Programming Command Driver Add On

Rockwell Automation provides the strongest protection of our customers installed base of product in the industry, The Command Central is another tool allowing seamless migration from Reliance Electric system architecture to our new Logix architecture, This is accomplished with maximum reuse of your investment in the existing Reliance system.

The 56AMXN module connects a Rockwell Automation ControlLogix back plane to an AutoMax DCS network or to an AutoMax Remote I/O network.

However, When using AutoMax Windows 2000 or NT for programming and monitoring the AutoMax System, a special driver card is required to communicate to the AutoMax network, This may require a separate programming station from that using RSLogix5000 or using a method to connect directly to the AutoMax processor for these functions.

Command Central, when added as a driver to the AutoMax WIN2000/NT workstation, will enable the user to program and monitor the AutoMax with the same communication modules that are used for the ControlLogix systems.

Command Central prepares the AutoMax commands to be sent out on ControlNet or Ethernet to a ControlLogix system. The 56AMXN module then prepares this command to be sent to the AutoMax through the DCS Network.

RSLogix 5000 as well as AutoMax NT will use RSLinx for interface through Ethernet or ControlNet for programming commands. A Logix Gateway and the 56AMXN module would be required to route these commands.

Command Central is an add-on software package to AutoMax WIN2000/NT (Version 3.9A and 4.3A).

The resultant connectivity will eliminate the "PCLink" module from being directly connected to the AutoMax network creating the need for a separate workstation. In addition, a single network connection would handle both ControlLogix programming and through the use of the 56AMXN "bridge" be able to deliver AutoMax programming commands through the DCS, Network.

#### Availability

See page 7-7

The Command Central is available as part of a value added solution through the Drive Systems business or your Local Drive Solution Centers.

**Rockwell Automation Drive Systems****MBCN (Multibus ControlNet Module)**

The MBCN is intended to augment a Reliance Electric control solution by providing faster throughput and a way to protect the AutoMax Systems investment when migrating to new control platforms.

**0-58820-2 MBCN**

The MBCN is a scanner class ControlNet v1.5 module for the MultiBus environment used in the AutoMax system controller.

The MBCN module allows an application running in a Reliance Electric AutoMax Controller to communicate with and control ControlNet I/O Devices.

The MBCN can support scheduled sends and receives to pass data to other nodes (processors) on the network. This is possible with PLC 5 and ControlLogix processors as well as other AutoMax racks.

**ControlNet**

ControlNet is the main control layer of the Rockwell Automation three layer model for enterprise-wide networking.

ControlNet provides features that are not available by any single network on the market today.

- High-speed (5 Mbits/sec) control and I/O network
- Improved I/O performance
- Improved peer to peer communications
- Deterministic - know when data will be transmitted

**General Features**

- Meets ControlNet International (CI) specifications
- LED support for module health, communication status (2) and I/O (connection status)
- Support for a minimum of 64 scheduled I/O connections
- Support a minimum of 32 unscheduled message connections (127 buffer locations)
- Total connections supported by the card at any one time is 64
- Support for a minimum of 5 outstanding UCMM messages
- Support provide for both scanner and adapter operation
- Dual media is supported
- Requires user to provide RSNetworkx version 3.21 or higher and RSLinx for network scheduling
- Supports A-B Flex and 1771 I/O devices
- Supports Reliance Electric Standard Drives GV3000 and FlexPak 3000
- Supports communication to any ControlNet International version 1.5 compliant and RSNetworkx supported device.

**Availability**

See page 7-7	The MBCN is available as part of a value added solution through the Drive Systems business or your Local Drive Solution Centers.
--------------	--

## Remote Access Dial-In Kits and Tutorial

### 1785-CH0RAD

The Allen-Bradley Remote Access Dial-In Modem Kit allows you to connect via modem to an AutoMax at a remote site. This will allow you to utilize all Version 3 or Version 4 executive functions from a remote site.

Allen-Bradley's remote access dial-in kits are designed to provide you with an industrial modem and architecture configuration. Each remote access dial-in kit offers standard hardware and cable configurations. In addition, each kit provides a detailed and intuitive remote access tutorial, which provides step-by-step instructions on hardware installation, modem initialization and software configuration.

While the remote access dial-in kits were designed and packaged for the PLC-5 product family, they can be used with AutoMax 6011 and 7010 processors using either Version 3 or Version 4 executive with very little effort.

- User to supply a 25 pin adapter to go between the personal computer and its modem. This adapter only passes lines 2,3 & 7. All other lines are open.
- Communicator speed is 9600 Baud.
- Version 4 systems require the use of Kermit as a communication interface. (Note: Kermit comes with Version 3 systems)

### Value Added Features

To reduce the set-up burden on our customers, the Remote Access Kit modems can be reconfigured by Rockwell Automation Technical Support via telephone. This feature eliminates the most difficult and problematic area of remote connectivity. In the event that the remote modem requires re-configuration, the remote access feature gives the customer the ability to modify the remote modem AT command set from a dial-up connection. This feature comes in handy when the device settings are modified due to processor fault or replacement. Remote configuration enables the user to re-configure the remote modem to the new processor settings and make the necessary changes.

### Remote Access Dial-In Kit Contents

Every Kit ordered is shipped with all the contents listed below.

1785-CH0RAD	
Qty	Contents
1	9F/25M pin Modem Cable
1	25M/25M pin Modem Cable
1	Tutorial CD-ROM (N/A to AutoMax)
2	Industrial Modem

To order kits, contact the Allen-Bradley Sales Office for your Region or contact your Local Allen-Bradley Distributor.

**Special Note** – If you are using V4 Automax Executive, contact Technical Support at **440-646-5800** to get the required version of Kermit software and line isolator to use with these modems.

**Reliance Phone Numbers for Technical Information**

<b>Rockwell Automation Group</b>	<b>Phone Number</b>
Rockwell Automation Drive Systems	See page 7-7 for your Local Drive Solutions Center
Reliance Standard Drives (V★S)	1-800-726-8112
Reliance Controls (AutoMax)	1-800-241-2886, 440-646-5800 Email: RACleAsktheexpert@ra.rockwell.com
Reliance AutoMate & Shark*	440-646-5800
GMS Westerville Operations	1-800-669-6119, 740-548-5733
Reliance Motor Support	Contact your local sales office
Reliance Service (Global Manufacturing Solutions)	Contact your local sales office
Training	Contact your local sales office

\*There is a charge for Legacy Product Support. For details, see  
<http://support.automation.rockwell.com/supportprograms/LGYSPT-PP001A-EN-P.pdf>

**Websites**

Reliance Electric	<a href="http://www.reliance.com">www.reliance.com</a>
Allen-Bradley	<a href="http://www.ab.com">www.ab.com</a>
Rockwell Software	<a href="http://www.software.rockwell.com">www.software.rockwell.com</a>
Rockwell Automation	<a href="http://www.rockwellautomation.com">www.rockwellautomation.com</a>



---

**Key Word Index**

---

45C1 Digital Rail	3-19	Rail I/O Digital Input Modules	3-33
45C630 Thumbwheel Switch Interface Module	3-20	Rail I/O Digital Output Modules	3-33
45C631 LED Interface Module	3-20	Rail I/O	3-3
57C328 Remote Head	3-18	Reflective Memory Networking	6-7
61C22 Local Head	3-18	Remote Input/Output Communications Network	2-10
A-B Data Highway Plus Module	2-8	Remote I/O Communications Module	2-11
A-B Interface Module	2-16	Remote I/O	3-3
A-B Remote I/O Scanner Module	2-12	Resolvers	3-11
AMETEK	6-4	R-NET Communications Network	2-13
Analog Input Modules	3-5	R-NET Processor Module	2-14
Analog Output Modules	3-10	Specialty I/O Modules	3-11
Analog Rail I/O Modules	3-19	SST	6-2
AutoMate Interface Module	2-15	Toledo Scale Interface Module	2-17
AutoMax Common Memory Cards	1-6	Training	7-2
AutoMax Connectivity	3-36	Variable Organizer	6-5
AutoMax Multibus Processors	1-4	VME Interface Card	6-3
AutoMax PC3000 Processor	1-5	VMIC	6-7
AutoMax Version 2 Programming Executive	4-7	VMR Software	6-5
AutoMax Version 3 Programming Executive	4-5	Weed Fiber-Optics	6-7
AutoMax Version 4 Programming Executive	4-3	X-Link	6-2
Block Task Viewer	6-5		
DCS Network Communications Module	2-3		
DCS-NET Communication Network	2-2		
DCS-Net Fiber Optic Network	2-7		
Delta Computer Systems, Inc.	6-6		
DeviceNet Module	6-4		
Digital Input Modules	3-19		
Digital Input Modules	3-4		
Digital Output Modules	3-19		
Digital Output Modules	3-4		
Drive Systems	7-7		
Ethernet Interface Module	2-17		
Fiber Optic Modem	6-7		
GE Fanuc Series 90-70	6-3		
GEMCO 1090 Programmable Limit Switch	6-4		
Global Manufacturing Solutions	7-4		
Hydraulic Servo Card	6-6		
Industrial Design Multibus Frequency Output Module	6-8		
Local I/O	3-3		
MaxPak III High-Speed Link Module	2-16		
MaxTools	6-5		
MaxView	6-5		
MDT Software- MASS AutoSaver™	6-6		
Modbus Interface Module	2-15		
Modbus Plus Interface Module	2-18		
Multibus Analog Input Modules	3-29		
Multibus Analog Output Modules	3-30		
Multibus ControlNet Module	2-18		
Multibus Digital Input Modules	3-27		
Multibus Digital Output Modules	3-28		
Multibus Frequency Output Module	6-8		
Multibus I/O	3-3		
OPC and DDE Servers	6-4		
PanelView 1200e and 1400e Operator Terminals and Software	5-5		
PanelView 550, 600, 900, 1000, 1400 Operator Terminals and Software	5-4		
PC Link Interface Module	2-5		
PICS Simulation Software	6-2		
Power Supplies	1-3		
Profibus Module	6-3		
Racks	1-2		
Rail Analog Input Modules	3-35		
Rail Analog Input/Output Modules	3-35		
Rail Analog Output Modules	3-35		

**Model Number Index**

---

45C1: 3-19, 23	57C372: 3-22, 26	57C655: 4-10
45C166: 3-19, 24, 34	57C373: 3-22, 26	57C656: 4-10
45C175: 3-26	57C375: 3-21, 26	57C657: 4-10
45C176: 3-26	57C376: 3-21, 26	61C22: 3-18, 23
45C2: 3-23	57C377: 3-22, 26	61C23: 3-23, 25
45C270: 7-4	57C380: 2-4	61C326: 7-5
45C271: 7-4	57C381: 2-4	61C345: 3-19, 25, 34
45C272: 7-4	57C385: 1-4, 5, 6	61C346: 3-19, 25, 34
45C273: 7-4	57C391: 4-7, 8, 9, 10	61C35: 3-34
45C3: 3-23	57C393: 4-9	61C350: 3-19, 25, 35
45C301: 7-4	57C400: 1-11	61C351: 3-19, 25, 35
45C305: 7-4	57C402: 1-11; 3-4, 21, 28	61C365: 3-19, 25, 35
45C307: 7-4	57C403: 1-11; 3-4, 21, 28	61C366: 3-19, 25, 35
45C4: 3-23	57C404: 1-11; 2-3, 4, 5, 7, 19	61C500: 1-11; 3-21, 27
45C40: 3-19, 23, 33	57C407: 1-11	61C501: 1-11; 3-4, 21, 27
45C410: 7-4	57C409: 1-11; 3-5, 21, 29	61C505: 3-21, 26
45C411: 7-4	57C410: 1-11; 3-10, 21, 30	61C506: 3-21, 26
45C42: 3-19, 23, 33	57C411: 1-11; 3-11, 22, 31	61C515: 1-11; 3-21, 27
45C43: 3-19, 23, 33	57C413: 1-2, 6, 8, 11	61C516: 1-11; 3-4, 21, 27
45C44: 3-19, 23, 33	57C414: 1-11; 2-15, 19	61C540: 1-11; 3-8, 9, 21, 29
45C46: 3-19, 23, 33	57C415: 1-11	61C542: 1-11; 3-8, 9, 21, 29
45C5: 3-23, 25	57C416: 1-11; 2-4, 11, 19; 3-3	61C544: 1-11; 3-15, 16, 22, 31
45C60: 3-19, 24, 33	57C417: 1-11; 2-15, 19	61C545: 3-16, 22, 26
45C62: 3-19, 24, 33	57C418: 1-11; 2-16, 19	61C546: 3-16, 22, 26
45C63: 3-19, 24, 33	57C419: 1-11; 3-4, 21, 27	61C547: 3-9, 21, 26
45C630: 3-20, 25	57C420: 1-11; 3-21, 28	61C548: 3-9, 21, 26
45C631: 3-20	57C421: 1-11; 3-12, 22, 30	61C549: 3-9, 21, 26
45C65: 3-19, 24, 33	57C422: 1-11; 3-13, 14, 22	61C550: 3-9, 26
45C66: 3-19, 24, 33	57C423: 1-2, 6, 8, 11	61C599: 1-7
45C67: 3-19, 24, 33	57C424: 1-11; 2-16	61C613: 1-11; 3-6, 7, 22, 32
45C68: 3-19, 24, 33 4	57C428: 1-11; 2-17, 19	J-3656: 4-10
5C69: 3-19, 24, 34	57C429: 1-11; 2-14, 19	J-3685: 4-10
45C70: 2-4	57C430: 1-11	J-3686: 4-10
45C71: 2-4	57C431: 1-2, 4, 8, 11; 3-3	J2-3006: 4-10
45C72: 2-4	57C435: 1-2, 4, 8, 11; 3-3	J2-3007: 4-10
45C73: 2-4	57C440: 1-11; 2-17, 19	J2-3049: 4-10
45C8: 3-23, 25	57C441: 1-11; 2-18, 19	J2-3066: 4-10
57407: 1-9	57C442: 1-11; 2-9, 19, 3-14	J2-3068: 4-10
57413: 1-9	57C443: 1-11; 2-12, 19; 3-3	J2-3080: 4-10
57652: 1-11	57C445: 2-5, 6, 19	J2-3092: 4-10
57C317: 49	57C490: 2-4, 2-19	J2-3096: 4-10
57C321: 4-10	57C493: 1-2, 3, 7, 11	J2-3104: 4-10
57C322: 4-10	57C494: 1-2, 3, 7, 11	S-3000: 4-10
57C323: 4-10	57C495: 1-9	S-3001: 4-10
57C328: 2-4; 3-3, 18, 23	57C496: 1-9	S-3002: 4-10
57C329: 2-4	57C497: 1-9	S-3003: 4-10
57C330: 2-4	57C498: 2-4, 2-19	
57C331: 1-2, 7	57C560: 1-5, 8	
57C332: 1-2, 7	57C565: 1-5	
57C334: 1-2, 7	57C570: 1-5, 8	
57C360: 3-11, 22	57C610: 4-3, 4, 5, 6, 9	
57C361: 3-11, 22	57C611: 4-9	
57C365: 2-7	57C625: 4-3	
57C366: 2-4, 7	57C650: 4-3, 10	
57C367: 2-7	57C651: 4-10	
57C368: 2-7	57C652: 4-10	
57C370: 3-21, 26	57C653: 4-10	
57C371: 3-21, 26	57C654: 4-10	

*For other model numbers, refer to appropriate section.*

This document located at:  
[www.reliance.com/pdf\\_elements/j415/](http://www.reliance.com/pdf_elements/j415/)

[www.rockwellautomation.com](http://www.rockwellautomation.com)

**Corporate Headquarters**

Rockwell Automation, 777 East Wisconsin Avenue, Suite 1400, Milwaukee, WI, 53202-5302 USA, Tel: (1) 414.212.5200, Fax: (1) 414.212.5201

**Headquarters for Allen-Bradley Products, Rockwell Software Products and Global Manufacturing Solutions**

Americas: Rockwell Automation, 1201 South Second Street, Milwaukee, WI 53204-2496 USA, Tel: (1) 414.382.2000, Fax: (1) 414.382.4444

Europe/Middle East/Africa: Rockwell Automation SA/NV, Vorstlaan/Boulevard du Souverain 36, 1170 Brussels, Belgium, Tel: (32) 2 663 0600, Fax: (32) 2 663 0640

Asia Pacific: Rockwell Automation, Level 14, Core F, Cyberport 3, 100 Cyberport Road, Hong Kong, Tel: (852) 2887 4788, Fax: (852) 2508 1846

**Headquarters for Dodge and Reliance Electric Products**

Americas: Rockwell Automation, 6040 Ponders Court, Greenville, SC 29615-4617 USA, Tel: (1) 864.297.4800, Fax: (1) 864.281.2433

Europe/Middle East/Africa: Rockwell Automation, Herman-Heinrich-Gossen-Strasse 3, 50858 Köln, Germany, Tel: 49 (0) 2234 379410, Fax: 49 (0) 2234 3794164

Asia Pacific: Rockwell Automation, 55 Newton Road, #11-01/02 Revenue House, Singapore 307987, Tel: (65) 6356 9077, Fax: (65) 6356 9011